

Classroom Connections to *TerraNova, The Second Edition*

A Resource Guide for Teachers



Grades 2–3

54381 Copyright © 2002 by CTB/McGraw-Hill LLC. All rights reserved.

**Mc
Graw
Hill** **CTB
McGraw-Hill**

TerraNova 
THE SECOND EDITION

Acknowledgments

CTB is indebted to the following for permission to use material in this book:

Images of photographs not otherwise acknowledged provided by © 1996 PhotoDisc, Inc.

"The Fishing Cat" by Patricia Scarry from *Richard Scarry's Best Story Book Ever*, pictures by Richard Scarry, copyright © 1950, 1955, 1958, 1960, 1961, 1963, 1964, 1965, 1967, 1968 by Random House, Inc. Copyright © 1967 by Richard Scarry. Used by permission of Golden Books, an imprint of Random House Children's Books, a division of Random House, Inc.

"The Party" from *Harry and the Lady Next Door* by Gene Zion, text copyright © 1960 by Gene Zion, illustrations copyright © 1960 by Margaret Bloy Graham. Used by permission.

"Do Animals Talk to Each Other?" from *Do Animals Take Baths?* text by Neil Morris, illustrations by Toni Goffe, copyright © 1995, 1994 Larousse plc. Used by permission of Reader's Digest Children's Publishing, Inc.

"Owl and the Moon" from *Owl at Home* by Arnold Lobel, copyright © 1975 by Arnold Lobel. Used by permission of HarperCollins Publishers.

Excerpts and photographs from *Once Upon a Time* by Eve Bunting, copyright © 1995. Published by Richard C. Owen Publishers, Katonah, NY; part of the "Meet the Author Collection." Photograph of Eve Bunting writing by John Pezaris, other photographs courtesy of Eve Bunting. Used by permission of Richard C. Owen Publishers. "The Wreck of the Hesperus" is by Henry Wadsworth Longfellow.

"Trial Run" from *Amelia's Flying Machine* by Barbara Shook Hazen, text copyright © 1977 by Barbara Shook Hazen. Reprinted by permission of the author.

Published by CTB/McGraw-Hill LLC, a subsidiary of The McGraw-Hill Companies, Inc., 20 Ryan Ranch Road, Monterey, California 93940-5703. Copyright © 2002 by CTB/McGraw-Hill LLC. All rights reserved. This publication or portions thereof may be reproduced, downloaded, and distributed as needed.

California Achievement Tests, Fifth Edition (CAT/5), Classroom Manager, Fox in a Box: An Adventure in Literacy, SUPERA, and *TerraNova* are registered trademarks, and Classroom Connections to *TerraNova*, CTB, and *InView* are trademarks of The McGraw-Hill Companies, Inc. Pre-LAS 2000 is a registered trademark of De Avila, Duncan and Associates. Balanced Assessment in Mathematics is a trademark of the Mathematics Assessment Resource Service.

All other brand and product names are the trademarks or registered trademarks of their respective companies and are not associated with the publisher of this publication.

Foreword

Please Note:

This CD-ROM includes the following materials from the print version of Classroom Connections to *TerraNova, The Second Edition, Grades 2–3*.

CD-ROM Table of Contents

Part 2 Items Illustrating Content—Item Writing Tips

Part 4 Student Practice Materials—Grade 2

Part 5 Student Practice Materials—Grade 3

Part 6 Scoring Guide

Part 7 Teaching Activities

Part 8 Using Test Results—Parents' Guide to Understanding *TerraNova, The Second Edition* Achievement Tests

To ease in your navigation of this CD-ROM, text is highlighted. Clicking on the highlighted text will bring you to a page of related material. For example, clicking on an item number in “Part 4 Student Practice Materials—Grade 2” will bring you to “Part 6 Scoring Guide” and the correct answer for that item.

The Classroom Connections pages may be downloaded and printed for your convenience. The pages are reproduced from the original print version and include their print version page numbers at the top of the page. When downloading and printing a series of pages from the CD, refer to the specific page numbers referenced in the Portable Document Format (PDF) file shown at the bottom of the screen. The downloaded pages will appear as they do in the print version of Classroom Connections.

For more information about CTB products, visit the CTB Web site at www.ctb.com.

Table of Contents

Part 2 Items Illustrating Content	
Item Writing Tips	2.57
Part 4 Student Practice Materials—Grade 2	
Student Practice Materials	4.2
Reading and Language Arts	
Directions	4.3
Student Practice Materials	4.5
Mathematics	
Directions	4.25
Student Practice Materials	4.27
Science	
Directions	4.39
Student Practice Materials	4.41
Social Studies	
Directions	4.47
Student Practice Materials	4.49
Part 5 Student Practice Materials—Grade 3	
Student Practice Materials	5.2
Reading and Language Arts	
Student Practice Materials	5.3
Mathematics	
Student Practice Materials	5.23
Science	
Student Practice Materials	5.35
Social Studies	
Student Practice Materials	5.43
Part 6 Scoring Guide	
Introduction	6.2
How to Use the Scoring Guide for Reading and Language Arts	6.3
How to Use the Scoring Guide for Mathematics	6.4
Grade 2	
Student Practice Materials Answer Key	6.5
Scoring Guides to the Student Practice Materials	
Reading and Language Arts	6.6
Mathematics	6.9
Science	6.12
Social Studies	6.15
Grade 3	
Student Practice Materials Answer Key	6.18
Scoring Guides to the Student Practice Materials	
Reading and Language Arts	6.19
Mathematics	6.22
Science	6.25
Social Studies	6.28

Part 7 Teaching Activities	
Introduction to the Teaching Activities	7.2
Description of the Elements in a Teaching Activity	7.3
Reading and Language Arts	
Teaching Activities	7.4
Mathematics	
Teaching Activities	7.37
Science	
Teaching Activities	7.61
Social Studies	
Teaching Activities	7.77
Answers to Student Worksheets	7.93
Part 8 Using Test Results	
Parents' Guide to Understanding <i>TerraNova, The Second Edition</i>	
Achievement Tests	8.18

Item Writing Tips

The classroom teacher may want to develop more practice items to supplement those offered in [Parts 4](#) and [5](#). These additional items would give students practice in test-taking skills and measure progress in the subjects they are currently studying in class.

The item writers at CTB/McGraw-Hill use specific and complex guidelines to develop items for a wide range of testing products. Below you will find a simple checklist to follow in developing items similar to those used in *TerraNova, The Second Edition*. You may want to make copies of the template on the next page to help you organize your items.

1. Choose skills from your course objectives.
2. Each item should test only one educational objective.
3. Write a clear and direct stem (question) that does not clue the answer to the item or to other items.
4. The item should have only one correct response.
5. The distractors (incorrect responses) should be clearly wrong, yet plausible.
6. All the responses should be logically and grammatically consistent. A response should not “stand out” as different in length or structure.
7. Ordering the items from simple to complex, or according to the sequence in the stimulus, can help students successfully build on their understanding of a given passage or stimulus.
8. Items should cover a range of skills and difficulty levels.

Example:

The Fishing Cat
by Patricia Scarry



A cat went down to the sea to fish.
He wanted to catch a whale.
Did he catch a big, big whale?

No!
He caught
a big, big log.

Stem → **1** What did the fishing cat do first?

Distractors → He built a boat.
→ He caught a whale.

Correct Response → He went to the sea.

□ Item Writing Template**Item Objective:** _____**Stimulus (if any):****Stem:****Answer Choices:**

(Correct Response and Distractors)

A**B****C****D**

Student Practice Materials

The purpose of Part 4 is to provide second-grade students with a useful practice experience and to provide teachers with an opportunity to assess the readiness of their students for the actual test. To achieve this goal, the practice materials are designed for flexible classroom use and can be tailored to suit specific student needs or curricular goals.

Both selected-response items and constructed-response items are represented in the practice materials, giving students a chance to become familiar with different item types. Students who have seen how the questions are formatted and phrased will feel more at ease when confronted with similar items in a formal testing situation.

The student practice materials in Part 4 can also be useful after the test has been administered. After identifying where improvement is needed, these materials can contribute to a successful remediation effort.

The practice materials are organized by content area and can be assembled and administered as a single test covering a variety of subjects, or each content area can be assigned as a single-subject quiz. Teachers also have the option of reviewing the practice materials with students before asking them to answer the questions, or they can simulate a real testing situation by having students complete the items without discussion.

Items within the student practice materials have been written for two separate grade levels. Because of a range of abilities within most school districts across the nation, CTB/McGraw-Hill does not identify the items by grade level so that teachers will feel comfortable using these materials with students of different ability levels within the classroom.



For those teachers who wish to write additional items of their own, a section called “**Item Writing Tips**” is included at the end of Part 2.

The answer key and scoring guide in Part 6 identify the content objective for each of the practice items in Parts 4 and 5. With this information, a teacher can determine in which areas students are performing well and in which areas additional practice is needed. After determining student needs, the teaching activities in Part 7 can be used as a way of reviewing the key concepts and skills covered in the *TerraNova* family of assessments. For information about using test results, see Part 8 of this binder.

In this exercise, we recommend that, even at the second-grade level, passages and reading items be read by the students. The directions are read aloud by the teacher and are found in front of each content area. For the mathematics items, teachers will need to provide each student with a centimeter/inch ruler.



The following practice materials are ready for duplication and immediate classroom use. For teachers who have access to a computer and printer, the Student Practice Materials are available on the CD-ROM located on the inside back cover of this binder.

READING AND LANGUAGE ARTS

THE FISHING CAT

SAY Here is a passage called “The Fishing Cat.” Read the first part of this story about a cat who wants adventure. Then answer **Numbers 1 through 3**. You may look back at the story if you need to.

When students have finished marking their answers for Number 3,

SAY Now read the rest of the story. Then answer **Numbers 4 through 6**. You may look back at the story if you need to. Stop after Number 6.

When students have finished marking their answers for Number 6,

SAY **Number 7.** I will read the question to you. The fishing cat was very clever. Find the word that has the same beginning sounds as “clever . . . clever.” Mark your answer.

For **Numbers 8 and 9**, find the word or words that best complete each sentence. Mark your answers.

When students have finished marking their answers for Number 9,

THE PARTY

SAY Here is a story about Harry the dog. Read the first part of the story. Then answer **Numbers 10 through 12**. You may look back at the story if you need to.

When students have finished marking their answers for Number 12,

SAY Now read the rest of the story. Then answer **Numbers 13 and 14**. You may look back at the story if you need to.

When students have finished marking their answers for Number 14,

SAY **Number 15.** Find the sentence that best completes the story. Mark your answer.

For **Number 16**, you will write your own answers. Here are some of the things that happened in the story about Harry and the lady. Fill in the two empty boxes by writing what Harry did in that part of the story. You may look back at the story.

When students have finished marking their answers for Number 16,

DO ANIMALS TALK TO EACH OTHER?

SAY Read this story. Then answer **Numbers 17 through 21**. You may look back at the story if you need to. Stop after Number 21.

When students have finished marking their answers for Number 21,

SAY **Number 22.** Find the sentence that is written correctly. Mark your answer.

Number 23. Find the words that best complete the sentence. Mark your answer.

SAY **Number 24.** Find the word that can take the place of the underlined words in the sentence. Mark your answer.

For Numbers 25 and 26, you will write your own answers.

Number 25. Look in the box for the names of animals you have read about in “Do Animals Talk to Each Other?” Use the names to answer the questions below. You may look back at the story. (*Pause.*)

Number 26. Choose the animal whose way of talking is most like the way people talk to each other. Write the animal’s name on the line below.

Now write a sentence telling why you think this animal’s way of talking is most like the way people talk to each other. Be sure to use capital letters when needed and the correct end mark. (*Pause.*)

Now you are going to practice answering different kinds of questions.

Number 27. Find the word that has the same vowel, or middle, sound as “bright . . . bright.” Mark your answer.

Number 28. You are going to find the root, or base, word. A root word is a word from which other words are made. Find the root, or base, word of singing. Mark your answer.

Number 29. Find and then mark the part of the sentence that needs to be changed. If no part needs to be changed, mark “None.” Mark your answer.

Number 30. Find the sentence that has the correct end mark. Mark your answer.

Number 31. Find the word that is spelled correctly and best completes the sentence. Mark your answer.

Student Name _____

Directions Read the first part of this story about a cat who wants adventure. Then answer Numbers 1 through 3.

The Fishing Cat

by Patricia Scarry



A cat went down to the sea to fish.
He wanted to catch a whale.
Did he catch a big, big whale?

No!
He caught
a big, big log.

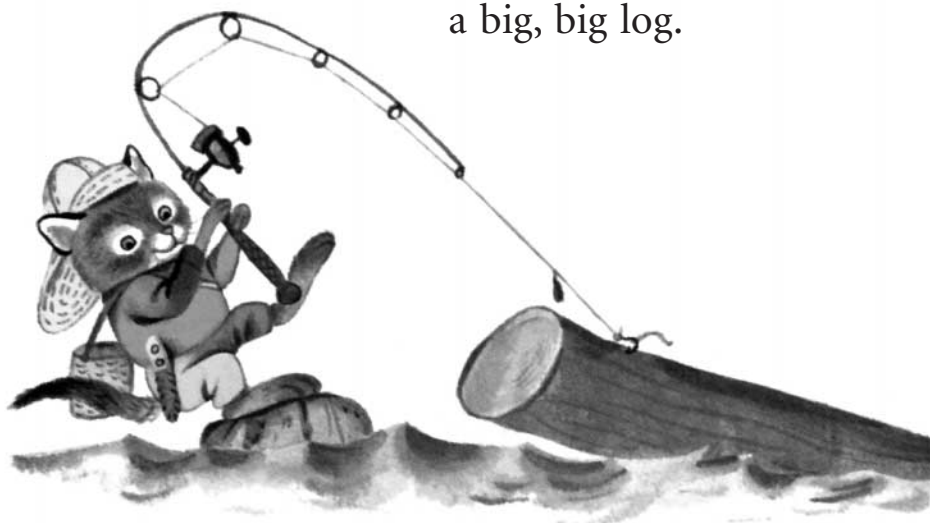

1 What did the fishing cat do first?

- He built a boat.
- He caught a whale.
- He went to the sea.

2 What did the fishing cat catch?

a log

a whale

a fish

3 What did the fishing cat want to catch?

a fish

a whale

a bird

Directions Now read the rest of the story. Then answer Numbers 4 through 6.

Did he toss the log back into the sea?



No. The cat did not.
He took out his knife and he cut the log.
He cut it here and there.
Now why did the cat do that?



He did it to make a fine fishing boat.

So LOOK OUT all you whales!

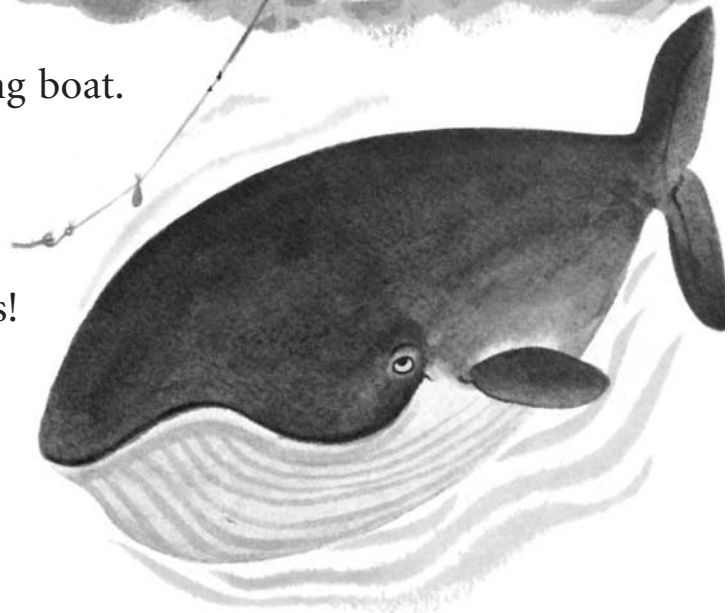

4 What did the cat do with the log?

- He built a house.
- He started a fire.
- He made a boat.

5 What will the cat probably do now?

- He will try to catch a whale.
- He will take a trip.
- He will learn to sail.

6 The story says

Did he toss the log back into the sea?

Toss means about the same as

- lose
- keep
- throw

7

chew

cloth

crash

Directions

For Numbers 8 and 9, find the word or words that best complete each sentence.

8

That cat is the _____ of all.

brave

bravest

braver

9

Two cats _____ and running.

jumping

is jumping

are jumping

Directions

Here is a story about Harry the dog. Read the first part of the story. Then answer Numbers 10 through 12.

The Party

by Gene Zion

Harry was a white dog with black spots. He loved all his neighbors, all except one. He did not love the lady next door.



The lady next door sang.
She sang high and loud.
When she sang, Harry's ears hurt.
She sang higher
than the peanut whistle.
When she sang, the peanut man
put his hands over his ears.



She sang louder
than the siren on the fire engine.
When she sang, the firemen
put their hands over their ears.
She sang higher and louder
than the cats sang.
When she sang, the cats ran away.

10 The story tells you that Harry loved

- to watch the fire engine
- the cats who sang loudly
- all his neighbors but one

11 What does the lady next door do that Harry does not like?







12 Who ran away when the lady sang?







Directions Now read the rest of the story. Then answer Numbers 13 and 14.



Harry tried everything to make her stop.
He howled under her window.
His friends howled too.
But it did not do any good.
The lady next door went on singing.
She sang higher and louder than ever.



One day Harry's family gave a party.
They invited the lady next door.
She came with her music.
When she started to sing,
Harry almost bit her leg.
But he bit the leg of the piano instead.

The family sent Harry
out of the room.
"You are a bad dog,"
they said.
Harry just wagged his tail.



As he walked to the door
some people said,
"Poor Harry."
But others whispered,
"The lucky dog!"

13 At the end of the story, Harry probably felt

- sad that he could not stay
- sorry that he had upset his family
- happy that he had to leave the room

14 Which of these TV shows would Harry probably not like?



15 Find the sentence that best completes the story.

My dad drives over the bridge every evening. _____.
In the morning, he comes back home.

- Then he works all night at the hospital.
- My mom leaves for work in the morning.
- That's when I help him make breakfast.

Directions For Number 16, you will write your own answers.

16 Here are some of the things that happened in the story about Harry and the lady. Fill in the two empty boxes by writing what Harry did in that part of the story. You may look back at the story.

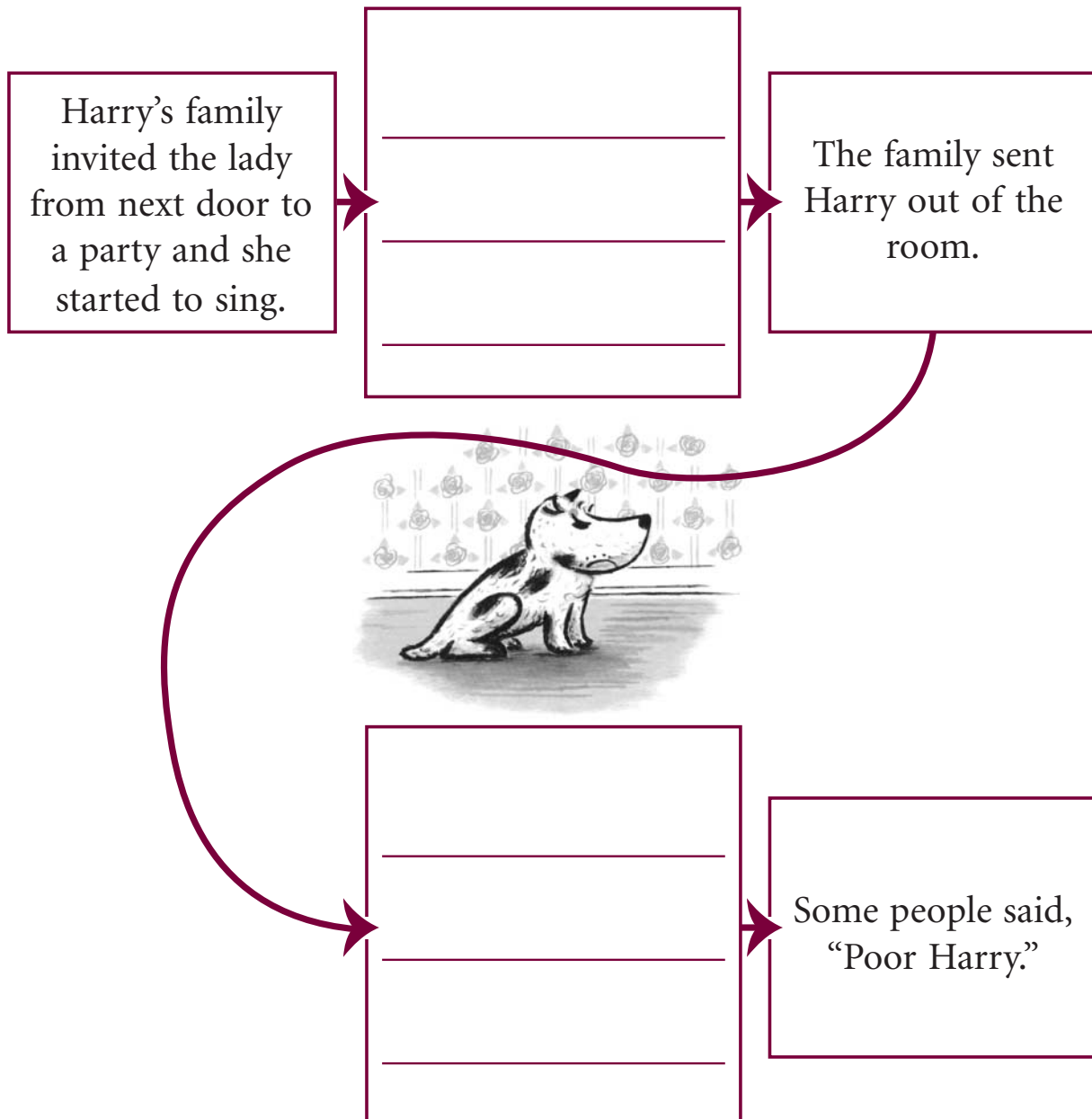

Directions Read this story. Then answer Numbers 17 through 21.

Do Animals Talk to Each Other?

Yes, but they don't use words. Animals have their own way of talking to each other. They use sounds, actions, and even smells to say things to each other.

Dolphins talk to each other using their own special language. To people, dolphin language sounds like a bunch of grunts, whines, whistles, and clicks.

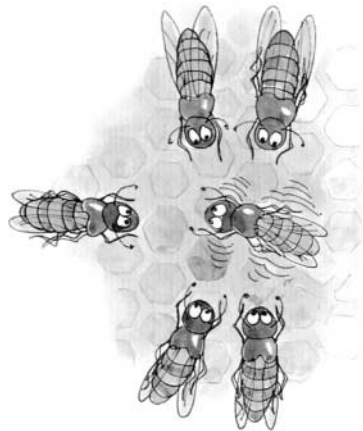
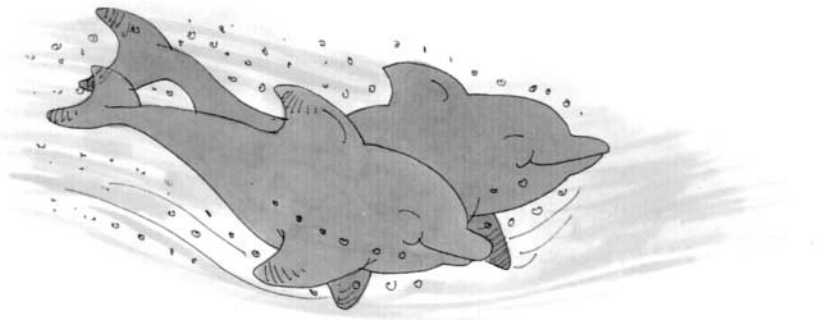

Honey bees do a dance to tell other bees where to find the best flowers for making honey.

Prairie dogs kiss each other to say hello! They sniff each other to see if they are from the same family.

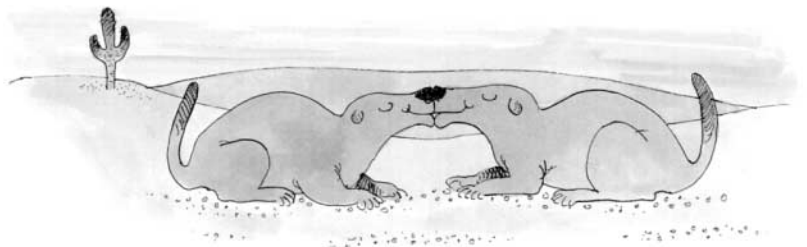

Cats can leave messages for each other by rubbing against things. When a cat rubs against a chair, he leaves a smell so other cats will know that he has been there.



A dog says that it is happy by wagging its tail from side to side.

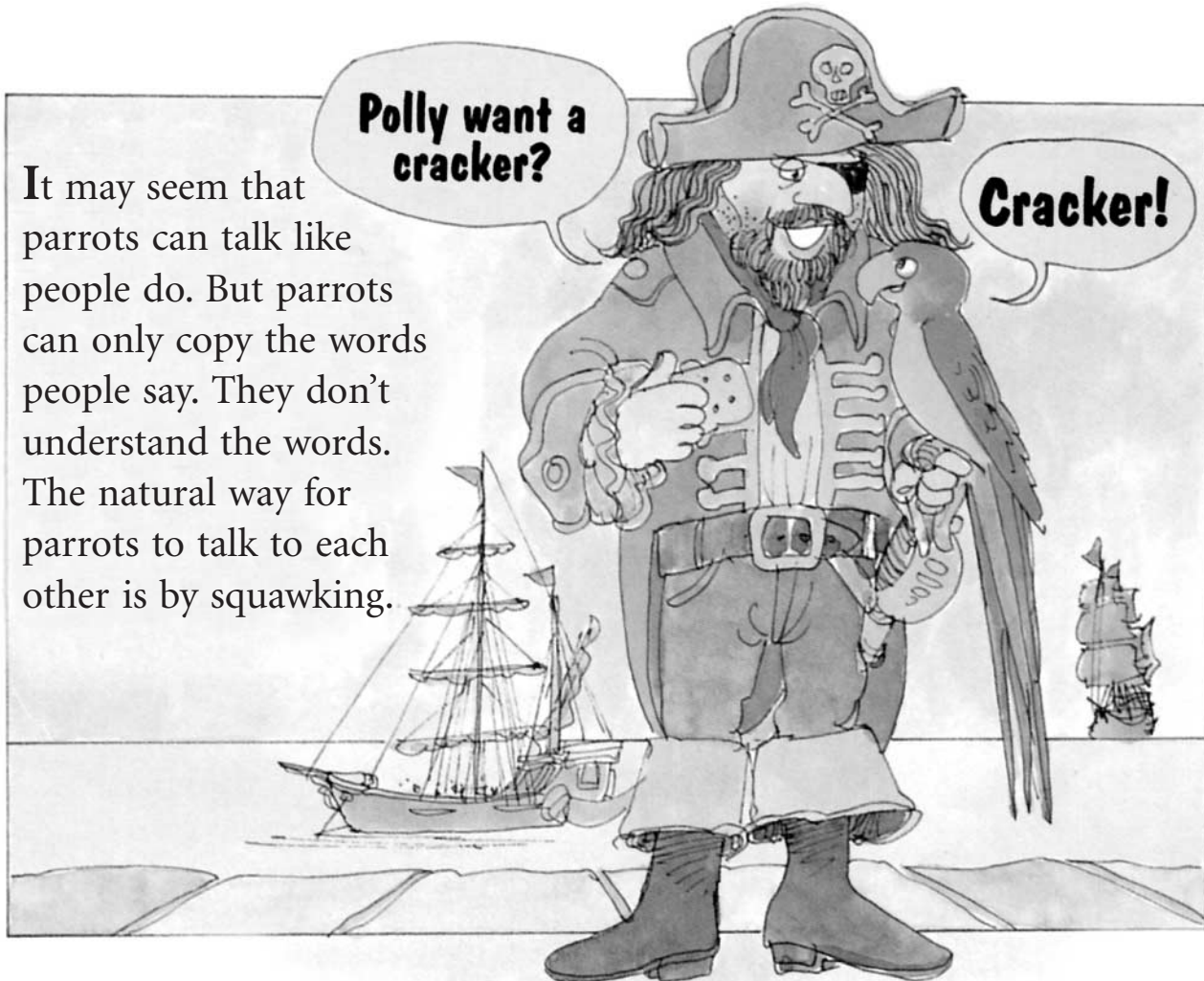

It may seem that parrots can talk like people do. But parrots can only copy the words people say. They don't understand the words. The natural way for parrots to talk to each other is by squawking.

17 This story is mostly about

- why dogs are friendly
- why cats rub furniture
- how animals move in different ways
- how animals talk without words

18 Which of these is like a way people sometimes greet each other?

- Prairie dogs kiss.
- Honey bees dance.
- Cats rub against things.
- Dogs wag their tails.

19 The story says that

parrots can only copy the words people say.

In this sentence, the word copy means

- understand
- squawk about
- make sounds like
- listen carefully to

20 Which of these could also be a name for this story?

- Why Honey Bees Dance
- How Animals Make Friends
- Why Dolphins Make Funny Sounds
- How Animals Say Things to Each Other

21 The story says that parrots talk to each other by

dancing

squawking

whistling

grunting

22 Find the sentence that is written correctly.

- In the birdhouse, trees growing.
- Many birds all together.
- The prettiest of all the birds.
- A green parrot is sleeping.

23 Find the words that best complete the sentence.

Yesterday the tigers _____ in the shade.

- are napping
- will nap
- were napping
- can nap



24 Find the word that can take the place of the underlined words in the sentence.

Let's share our peanuts with Ben the elephant.

- | | | | |
|-----------------------|-----------------------|-----------------------|-----------------------|
| him | me | them | us |
| <input type="radio"/> | <input type="radio"/> | <input type="radio"/> | <input type="radio"/> |

Directions For Numbers 25 and 26, you will write your own answers.

25 Look in the box for the names of animals you have read about in
Do Animals Talk to Each Other?

Use the names to answer the questions below.
 You may look back at the story.



Which animal talks by dancing? _____

Which animal talks by squawking? _____

Which animal talks by clicking? _____

26

Choose the animal whose way of talking is most like the way people talk to each other. Write the animal's name on the line below.

Now write a sentence telling why you think this animal's way of talking is most like the way people talk to each other. Be sure to use capital letters when needed and the correct end mark.

Directions Now you are going to practice answering different kinds of questions.

27

dirt

rice

wing

bill

28

Find the root, or base, word of singing.

ng

ing

ging

sing

29

We live in | a small house in | kansas city.

None

30 Find the sentence that has the correct end mark.

- The hole is over there,
- Watch out for that hole!
- Didn't you see the hole.
- The hole is very deep

31 Find the word that is spelled correctly and best completes the sentence.

Ice cream comes in many _____ flavors.

- different
- differant
- differint
- differunt



MATHEMATICS

Number 1. Put your finger on number 1. Look at the circles. Which circle has squares and triangles on it? Mark your answer.

Number 2. Look at the elephants. Sam saw these elephants. How many elephants did Sam see? Mark your answer.

Number 3. Which place value chart correctly shows the number 523? Mark your answer.

Number 4. Look at the numbers on the chalkboard. What number is shown by the group of numbers on the chalkboard? Mark your answer.

Number 5. Look at the problem and the numbers next to it. Solve the problem. Mark your answer.

Number 6. The same number is missing from each number sentence. What number will make both number sentences true? Mark your answer.

Number 7. Marian's hamster eats 3 scoops of food each day. Which of these shows how to find the total number of scoops of food the hamster will eat in 4 days? Mark your answer.

Number 8. Look at the books in the box. Cindy bought all 4 books. How much did she spend all together? Mark your answer.

Number 9. Julie made a fact family. Which number sentence is missing from her fact family?

Number 10. Look at the calendar. On what day of the week did Mr. Brown's class go to the zoo? Mark your answer.

Number 11. Teddy's group solved 10 problems and Keisha's group solved 27 problems. About how many problems did they solve all together? Mark your answer.

Number 12. David is measuring the length of his desk. Which measurement is not needed to help David find the length of his desk? Mark your answer.

Number 13. About how many jumps long is the school bus?

Number 14. Tim is making a chart that shows the number of wheels on his toy cars. Which group of numbers completes the chart correctly?

Number 15. Josh's group earned 40 points in a math contest. Gina's group earned 40 points more than Josh's group. Which graph shows the correct score of Gina's group? Mark your answer.

Number 16. Look at the graph. Uncle Henry gives his ponies carrots as treats. After a pony gives 50 rides in a month, it is given an apple. How many more rides does Prince need to give before receiving an apple? Mark your answer.

Number 17. Look at the graph. On Saturday, 10 chicks hatched. How many pictures will Farmer Brown need to add to his graph for Saturday? Mark your answer.

SAY **Number 18.** Charlie bought a pen for 56 cents. Look at the group of coins. Circle the coins that add up to 56 cents.

Give students ample time to complete the first part of the item.

SAY In the box below, add up the coins you circled to make 56 cents.

Number 19. Look at the rectangle below. Draw two lines on the rectangle to divide it into 4 triangles.

Number 20. Erin bought a box of erasers. Then she bought 3 more erasers. She now has 7 erasers all together. How many erasers are in the box? Fill in your answer.

Give students ample time to complete the first part of the item.

SAY How many erasers are in 3 boxes? Fill in your answer.

Student Name _____

1

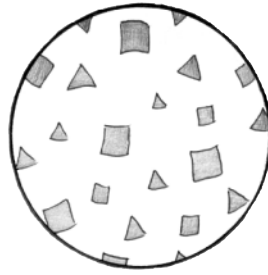
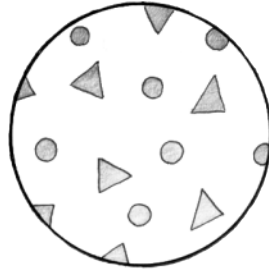
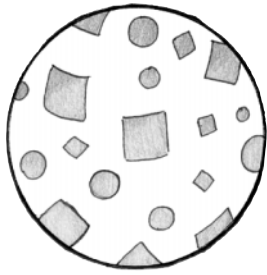

2

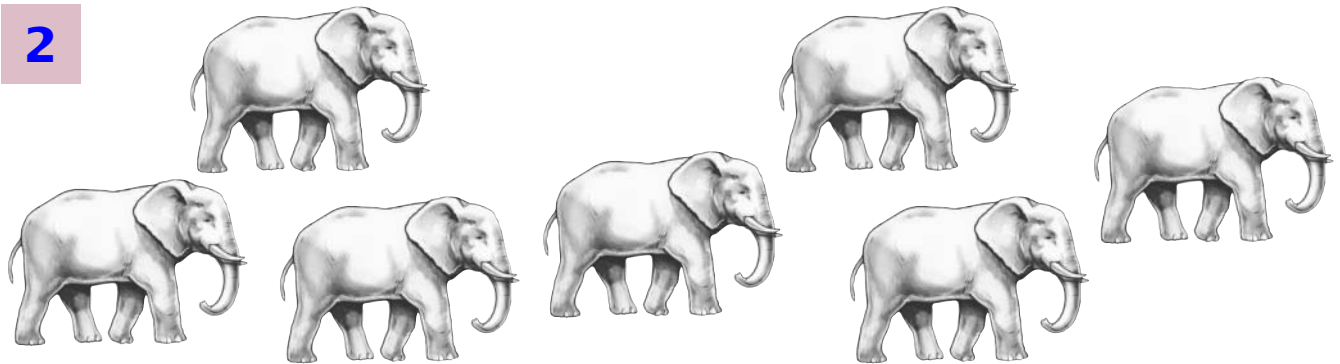

6

7

8

9

Copyright © 2002 by CTB/McGraw-Hill LLC.
This page may be reproduced for educational purposes only.

3

hundreds	tens	ones
●	●	●
●	●	●
●		●
		●
		●
		●

hundreds	tens	ones
●	●	●
●	●	●
●	●	
●		
●		

hundreds	tens	ones
●	●	●
●	●	●
	●	●
	●	
	●	
	●	

hundreds	tens	ones
●	●	●
●	●	●
●	●	●
●		●
●		

4

- 763
- 376
- 637
- 736

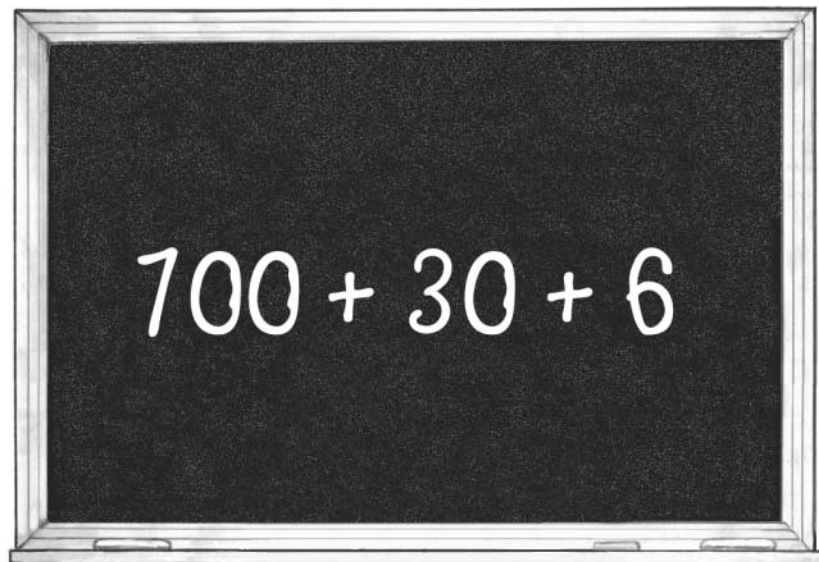

5

$$12 - 8 =$$

4
 16
 6
 20

6

$$\square + 10 = 15$$

$$8 + \square = 13$$

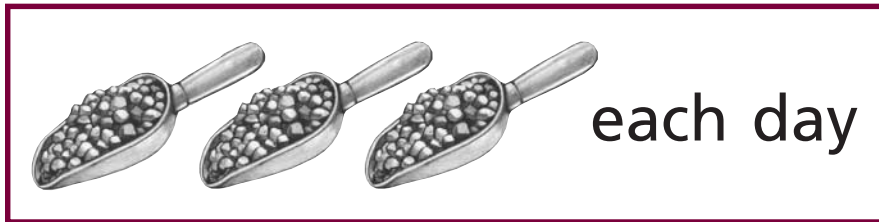
0
5
8
21
7

$$4 + 3$$

$$4 + 4$$

$$3 \times 4$$

$$4 \times 4$$

8

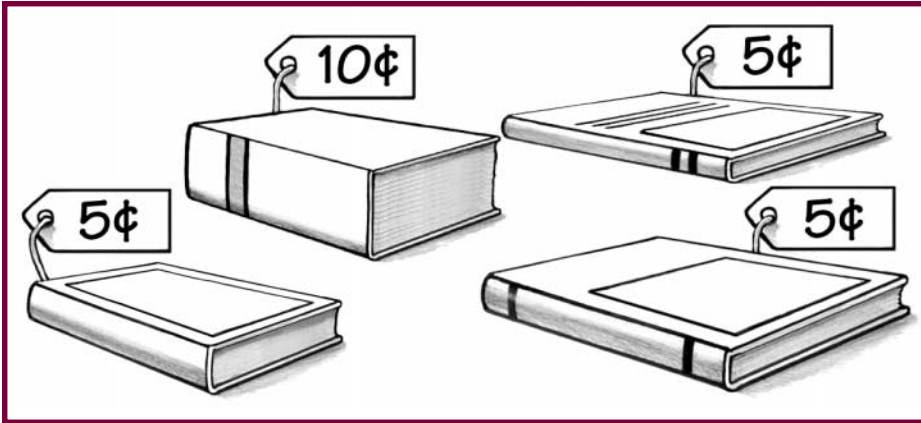

9

Fact Family

$9 + 5 = 14$

$5 + 9 = 14$

$14 - 5 = 9$

?

$14 + 5 = 19$

$14 + 9 = 23$

$9 - 5 = 4$

$14 - 9 = 5$

10

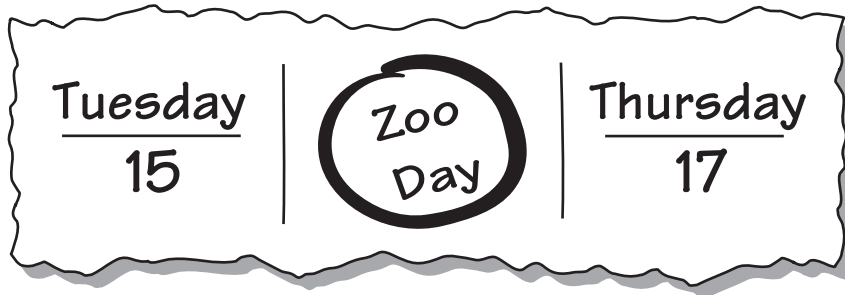

Monday

Friday

Wednesday

Thursday

11

10

30

40

60

12

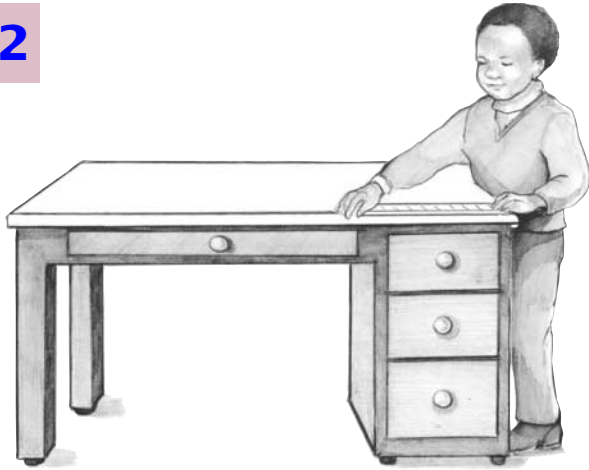

○



○

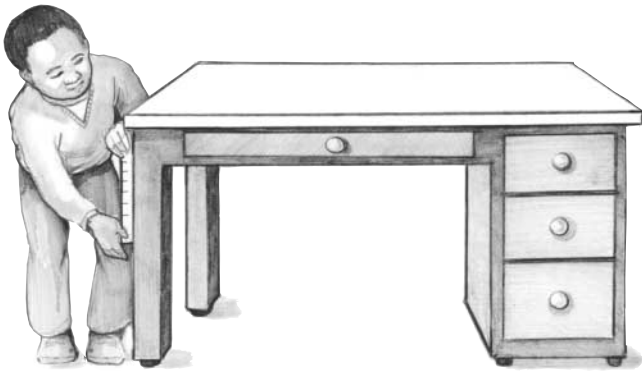

○

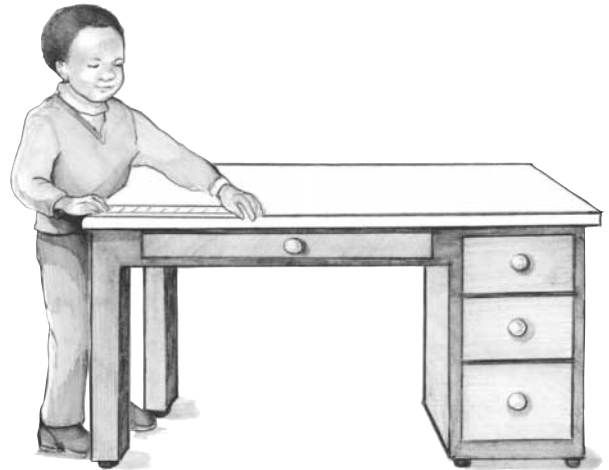

○

13

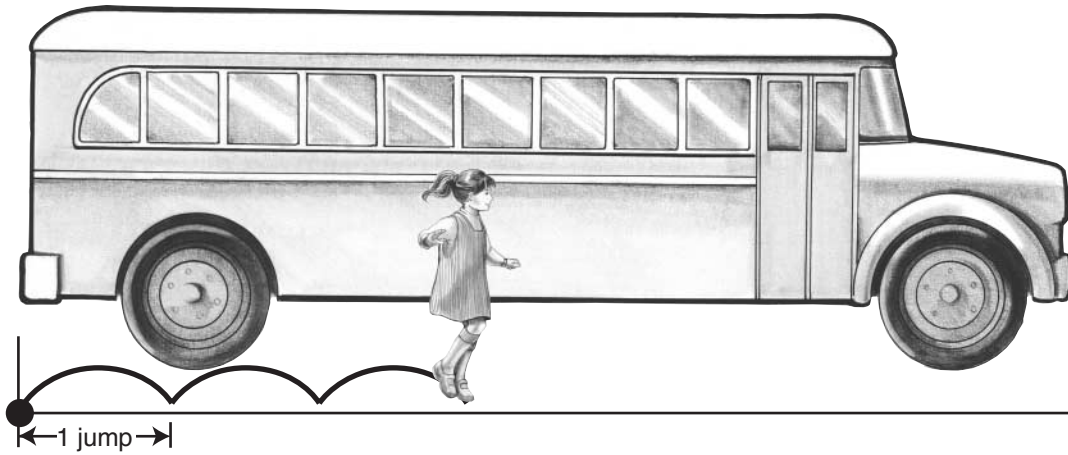

4



7





10



15

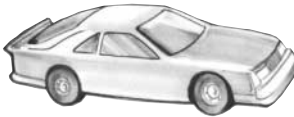

 Number of cars	1	2	3	4	5
 Number of wheels	4	8			

14

- 12, 16, 20
- 12, 16, 18
- 10, 14, 18
- 10, 12, 16

15

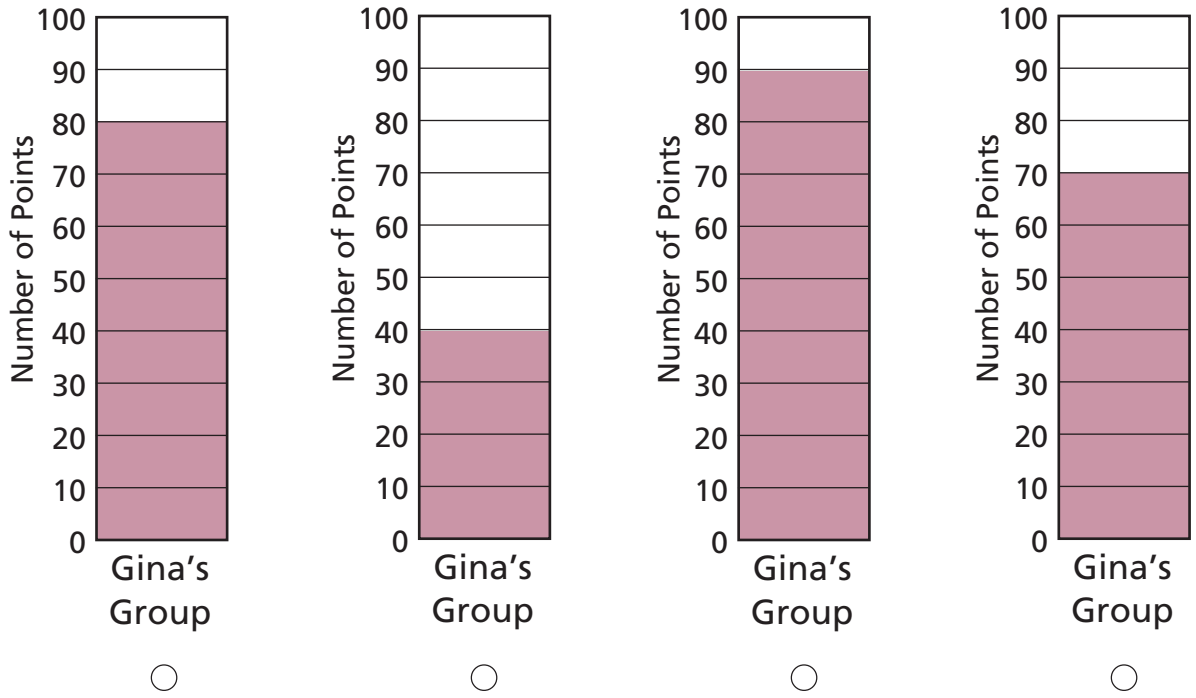



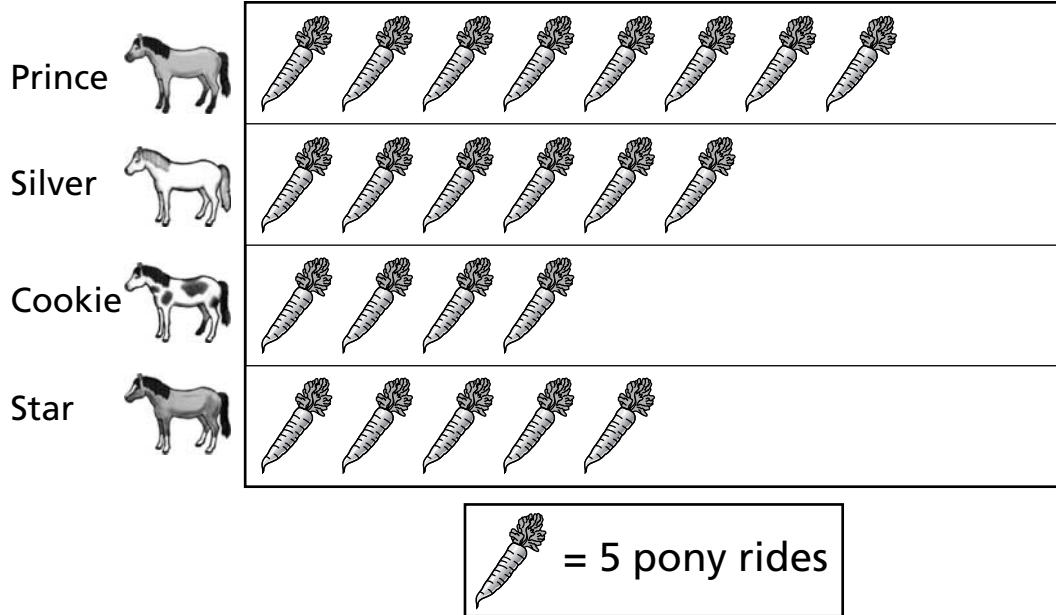

Number of Pony Rides in May

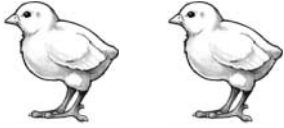

16

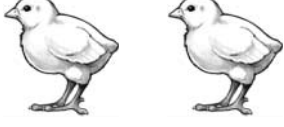
- 2
- 10
- 20
- 42

Day	Chicks Hatched
Monday	
Tuesday	
Wednesday	
Thursday	
Friday	
Saturday	

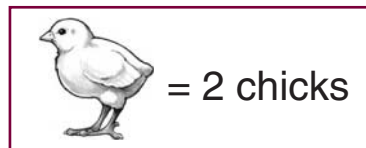

17

2



5



10



20



18

Charlie bought a pen for 56¢. Look at the group of coins. Circle the coins that add up to 56¢.



In the box below, add up the coins you circled to make 56¢.

19

Look at the rectangle below.



Draw 2 lines on the rectangle to divide it into 4 triangles.

20

Erin bought a box of erasers. Then she bought 3 more erasers. She now has 7 erasers all together.

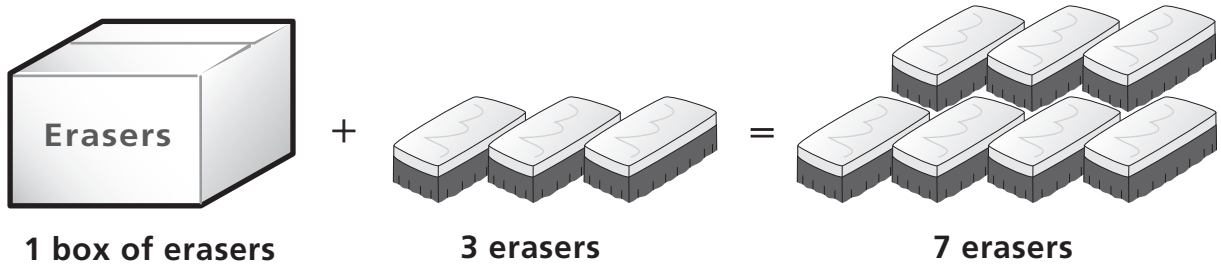

How many erasers are in the box? _____ erasers



How many erasers are in 3 boxes? _____ erasers

SCIENCE



Number 1. Look at the pictures. Find the tool that was designed to pick up food. Mark your answer.

Number 2. Look at the pictures. Which of these uses electricity as a source of energy? Mark your answer.

Number 3. Look at the pictures. Find something that would be most helpful for looking at the stars in the sky. Mark your answer.

Number 4. For Number 4, look at the graph. The graph shows the amount of water in each of four pots. Which pot has the least amount of water—pot A, pot B, pot C, or pot D? Mark your answer.

Number 5. Look at the animals in the box. Now look at the other animals below. Find the animal that is most like the ones in the box. Mark your answer.

Number 6. Look at the pictures. Find something that can be used to change a liquid to a gas. Mark your answer.

Number 7. Look at the pictures. Each container has the same amount of water in it. From which container will the water evaporate fastest? Mark your answer.

Number 8. Look at the pictures. Find the picture that shows where the moon gets its light. Mark your answer.

Number 9. If you were eating hot soup, which kind of spoon would warm up the fastest—a wooden spoon, a metal spoon, a plastic spoon, or a glass spoon? Mark your answer.

Number 10. The word precipitation is sometimes used to describe the weather. Look at the pictures. Which picture shows precipitation? Mark your answer.

Number 11. Look at the picture of the plant. What part of this plant connects the flower to other parts of the plant—the bulb, the stem, a leaf, or the roots? Mark your answer.

Number 12. Look at the picture in the box. It shows a glass with ice cubes in it. Now look at the other pictures below. Which picture shows how much water will be in the glass just after the ice cubes have melted? Mark your answer.

Number 13. Look at the pictures. Write a P on the line under the thing that is made of paper. (*Pause.*)

Write a W on the line under the thing that is made of wood. (*Pause.*)

Write an R on the line under the thing that is made of rubber.

Number 14. Look at the picture of the rabbit. Now look at the other pictures. Circle the parts of the rabbit that help it know it may be in danger.

Number 15. You want to do an experiment to find out if adding a tablespoon of baking soda to a cup of vinegar changes the temperature of the vinegar. Look at the pictures. Circle the things that would help you do this experiment.

Student Name _____

1

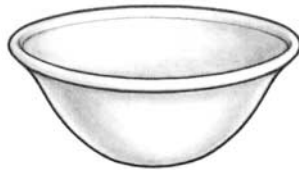
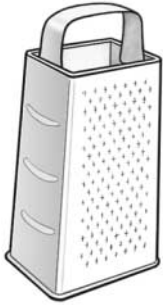

2



3



4 Which pot has the least amount of water?

- pot A
- pot B
- pot C
- pot D

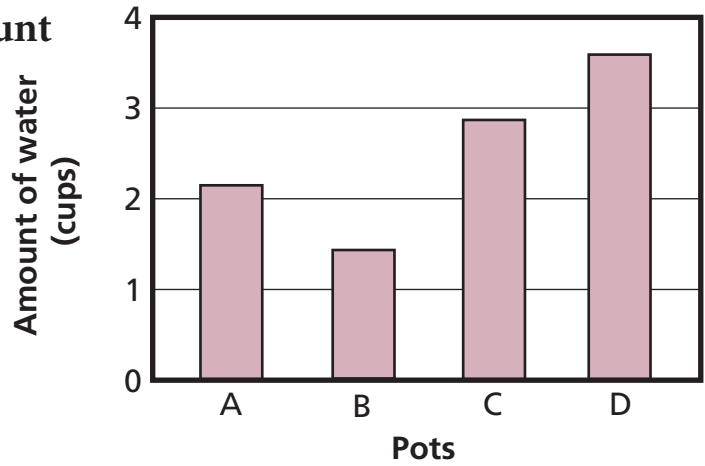

5



6

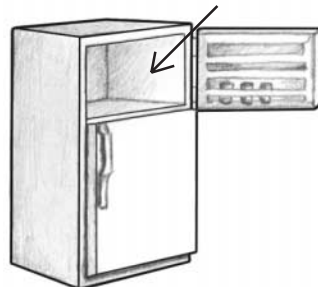

7



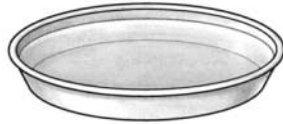





8



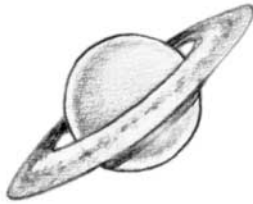





9

If you were eating hot soup, which kind of spoon would warm up the fastest?

- a wooden spoon
- a metal spoon
- a plastic spoon
- a glass spoon

10



○



○



○



○

11

What part of this plant connects the flower to other parts of the plant?

- bulb
- stem
- leaf
- roots



12



13







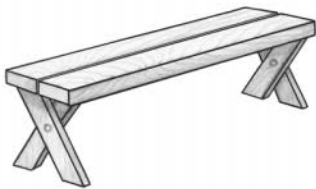



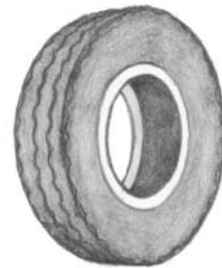

Copyright © 2002 by CTB/McGraw-Hill LLC.
This page may be reproduced for educational purposes only.

14

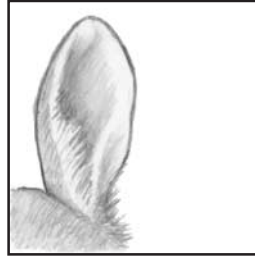
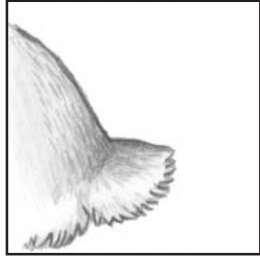

15

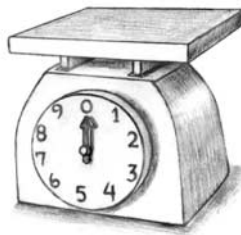
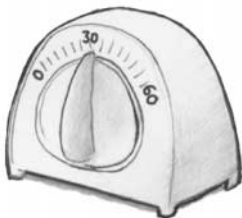
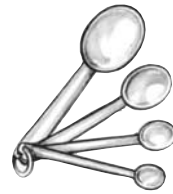

SOCIAL STUDIES

SAY A class voted on ideas for ways to raise money for a class trip. Look at the graph. The graph shows how many students voted for each idea. The ideas are a book sale, a candy sale, a carnival, a recycling project, and a T-shirt sale. Each check mark stands for one vote. We will use the graph to answer the next few questions.

Number 1. Put your finger on Number 1 below the graph. Look at the graph. How many students voted to have a candy sale? Mark your answer.

Number 2. Look at the graph again. What will the students probably do to raise money? Will they have a book sale, a candy sale, a carnival, a recycling project, or a T-shirt sale? Mark your answer.

Number 3. Look at the graph again. How many students voted for an idea that will help save natural resources? Mark your answer.

Look at the next page. These pictures show how apple juice is made and brought to stores. Look at the pictures. These pictures are labeled with the letters A, B, C, and D. We will use the pictures to answer the next few questions.

Number 4. Put your finger on Number 4 under the pictures. Look at the pictures. What kind of worker is shown in Picture A? Is it a factory worker, a farm worker, a store worker, or a truck driver? Mark your answer.

Number 5. Which picture shows the apple juice being made? Is it Picture A, B, C, or D? Mark your answer.

Number 6. Look at the pictures again. What probably happens between Pictures B and C? The answer choices are as follows: workers put apple juice into bottles; farmers plant apple trees; workers send apples to a juice factory; and people drink apple juice. Mark your answer.

Number 7. Listen. Writing and talking are ways people communicate with other people. Look at the pictures. Which picture shows what people used to communicate with others the longest time ago? Mark your answer.

Number 8. Long ago, pioneers traveled across America to find new homes. What did pioneers use long ago to travel west? Did they use cars, trucks, jet airplanes, or covered wagons? Mark your answer.

Put your finger on Number 9 at the top of the next page.

Number 9. What do we call rules for a community, state, or country? Are they called laws, freedoms, services, or wants? Mark your answer.

Number 10. I live in a country that is south of most of the United States. Most people here speak Spanish. Where do I live? Do I live in China, India, Mexico, or Italy? Mark your answer.

Number 11. People use money to buy things they want and things they need. Which of these things is a need? Mark your answer.

Number 12. Taxes provide money that is used to help everyone in the community. Which of these things is paid for by taxes? Mark your answer.

Look at the next page. Picture A shows how a city looked a long time ago and Picture B shows the same area of the city today. We will use these pictures to answer Number 13.

Number 13. Put your finger on Number 13. Write two ways that the pictures show how this city has stayed the same over time.

Now write two ways that the pictures show how the city has changed over time.





Look at the chart on the next page. The chart shows the number of people who signed up to work at different booths at a school carnival. Four people signed up to work at the Games Booth. Eight people signed up to work at the Food Booth, and five people signed up to work at the Drinks Booth. We will use this chart to answer Number 14.

Number 14. Put your finger on Number 14. This bar graph shows some of the information in the chart, but it is not finished. Use the chart to complete the bar graph.

Number 15. Put your finger on Number 15. This picture shows people celebrating the 4th of July holiday. What do people in the United States celebrate on the 4th of July? Write your answer on the lines.

Student Name _____

Raising Money

Book Sale		✓✓✓✓
Candy Sale		✓✓
Carnival		✓✓✓✓✓✓
Recycling Project		✓✓✓
T-shirt Sale		✓✓✓✓

✓ = one vote

1

- 2
- 3
- 4
- 6

2

- book sale
- candy sale
- carnival
- T-shirt sale

3

- 2
- 3
- 4
- 6

Apple Juice

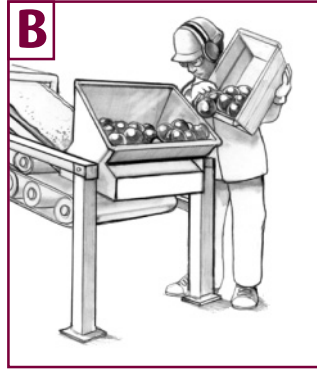

4

factory worker

farm worker

store worker

truck driver

5

A

B

C

D

6

Workers put
apple juice
into bottles.

Farmers
plant apple
trees.

Workers send
apples to a
juice factory.

People
drink apple
juice.

In the Past

7**8**

What did pioneers use long ago to travel west?

- cars
- trucks
- jet airplanes
- covered wagons

Do You Know?

9

laws

freedoms

services

wants

10

I live in a country that is south of most of the United States.
Most people here speak Spanish. Where do I live?

- China
- India
- Mexico
- Italy

11



12

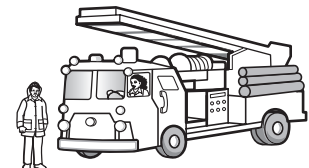
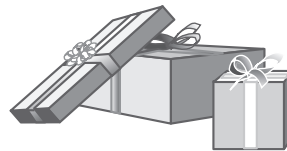

Long Ago and Today



Picture A



Picture B

13 Write two ways that the pictures show how the city has stayed the same over time.

• _____

• _____

Now write two ways that the pictures show how the city has changed over time.

• _____

• _____

School Carnival Helpers

Booth	Number of Helpers
Games	4
Food	8
Drinks	5

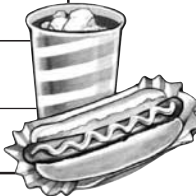

14 Use the chart to complete the bar graph.

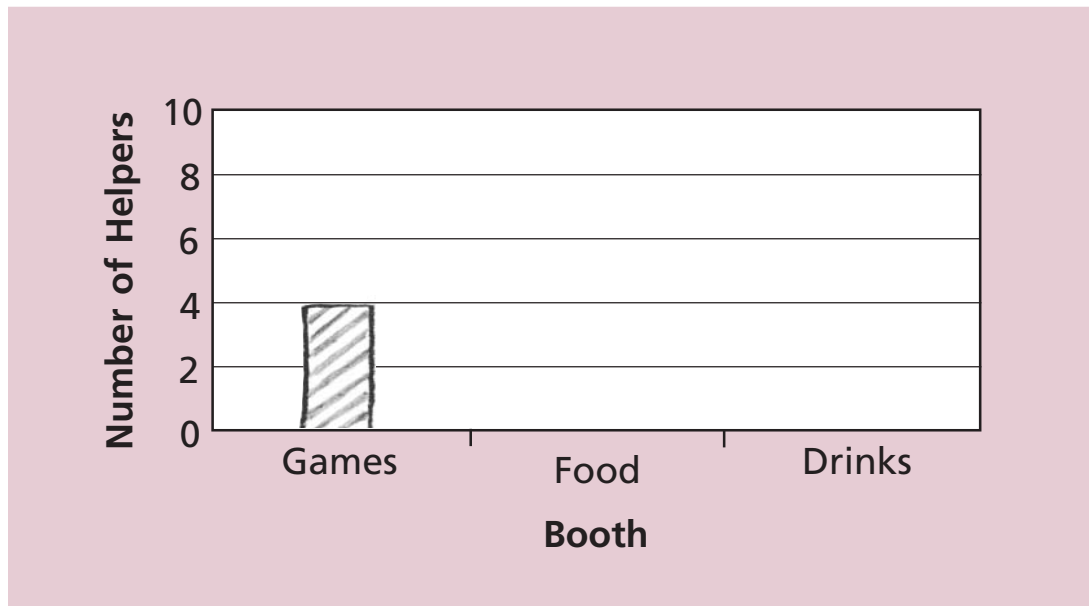

**15**

What do people in the United States celebrate on the 4th of July?

Student Practice Materials

The purpose of Part 5 is to provide third-grade students with a useful practice experience and to provide teachers with an opportunity to assess the readiness of their students for the actual test. To achieve this goal, the practice materials are designed for flexible classroom use and can be tailored to suit specific student needs or curricular goals.

Both selected-response items and constructed-response items are represented in the practice materials, giving students a chance to become familiar with different item types. Students who have seen how the questions are formatted and phrased will feel more at ease when confronted with similar items in a formal testing situation.

The student practice materials in Part 5 can also be useful after the test has been administered. After identifying where improvement is needed, these materials can contribute to a successful remediation effort.

The practice materials are organized by content area and can be assembled and administered as a single test covering a variety of subjects, or each content area can be assigned as a single-subject quiz. Teachers also have the option of reviewing the practice materials with students before asking them to answer the questions, or they can simulate a real testing situation by having students complete the items without discussion. For the mathematics items, teachers will need to provide each student with a centimeter/inch ruler.

Items within the student practice materials have been written for two separate grade levels. Because of a range of abilities within most school districts across the nation, CTB/McGraw-Hill does not identify the items by grade level so that teachers will feel comfortable using these materials with students of different ability levels within the classroom.



For those teachers who wish to write additional items of their own, a section called “Item Writing Tips” is included at the end of Part 2.

The answer key and scoring guide in [Part 6](#) identify the content objective for each of the practice items in [Parts 4](#) and [5](#). With this information, a teacher can determine in which areas students are performing well and in which areas additional practice is needed. After determining student needs, the teaching activities in [Part 7](#) can be used as a way of reviewing the key concepts and skills covered in the *TerraNova* family of assessments. For information about using test results, see [Part 8](#) of this binder.



The following practice materials are ready for duplication and immediate classroom use. For teachers who have access to a computer and printer, the Student Practice Materials are available on the CD-ROM located on the inside back cover of this binder.

Student Name _____

Directions Read this story by Arnold Lobel. Then answer Numbers 1 and 2.

Owl and the Moon

by Arnold Lobel



One night
Owl went down
to the seashore.
He sat on a large rock
and looked out at the waves.
Everything was dark.
Then a small tip
of the moon
came up
over the edge of the sea.
Owl watched the moon.
It climbed higher and higher
into the sky.
Soon the whole, round moon
was shining.
Owl sat on the rock
and looked up at the moon
for a long time.
“If I am looking
at you, moon,
then you must be
looking back at me.
We must be
very good friends.”

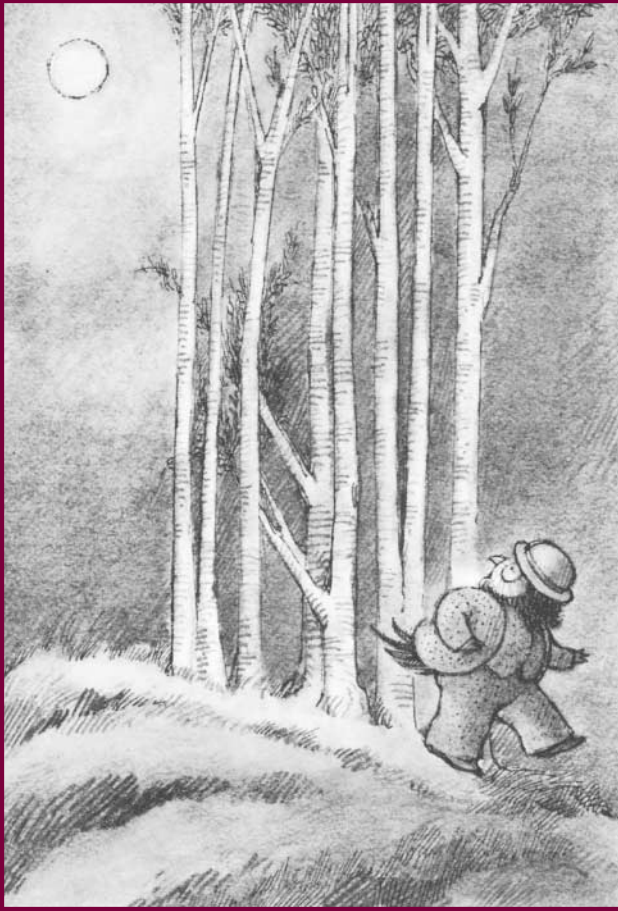

The moon did not answer,
but Owl said,
“I will come back
and see you again, moon.
But now I must go home.”
Owl walked down the path.
He looked up at the sky.
The moon was still there.
It was following him.

“No, no, moon,” said Owl.
“It is kind of you
to light my way.
But you must stay up
over the sea
where you look so fine.”

1 What happens first in the story?

- The moon rises over the sea.
- The moon follows Owl home.
- Owl talks to the moon.
- Owl goes down to the seashore.

2 Owl talks to the moon because

- he knows the moon is lonely
- he thinks the moon is looking at him
- the moon says hello
- the moon begins to go away

Directions Now read the rest of the story. Then answer Numbers 3 through 10.

Owl walked on a little farther.
He looked at the sky again.
There was the moon
coming right along with him.
“Dear moon,” said Owl,
“you really must not
come home with me.
My house is small.
You would not fit
through the door.
And I have nothing
to give you for supper.”

Owl kept on walking.
The moon
sailed after him
over the tops of the trees.
“Moon,” said Owl,
“I think that
you do not hear me.”

Owl climbed
to the top of a hill.
He shouted
as loudly as he could,
“Good-bye, moon!”



The moon went behind
some clouds.
Owl looked and looked.
The moon was gone.
“It is always
a little sad
to say good-bye to a friend,”
said Owl.

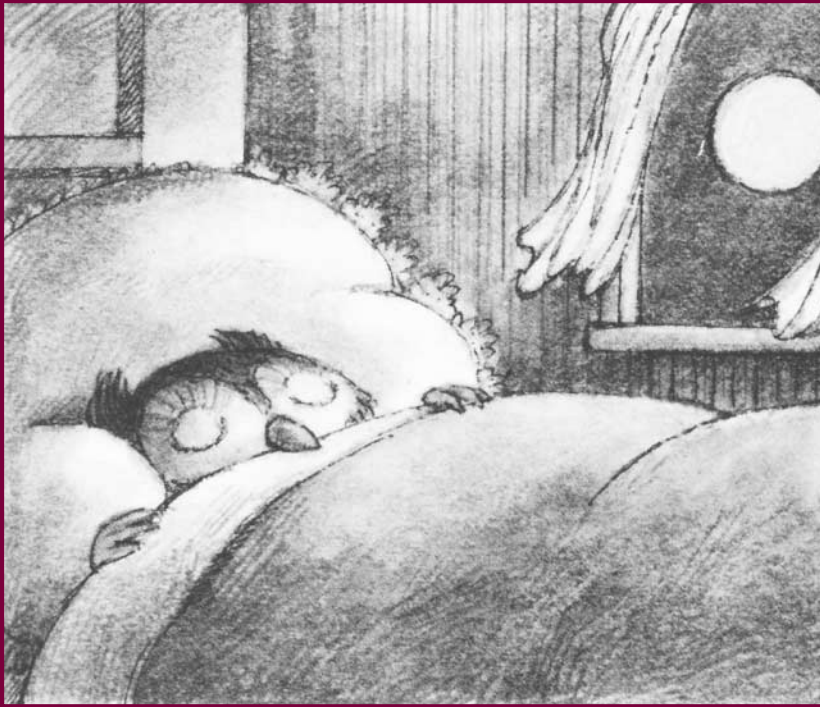

Owl came home.
 He put on his pajamas
 and went to bed.
 The room was very dark.
 Owl was still feeling sad.
 Then Owl put his head
 on the pillow
 and closed his eyes.
 The moon was shining
 down through the window.
 Owl did not
 feel sad at all.

3 How does Owl try to make the moon stop following him?

- Owl goes home another way.
- Owl tells the moon it is too small.
- Owl walks back to the seashore.
- Owl climbs a hill and shouts, "Good-bye."

4 When the moon goes behind some clouds, Owl believes it

- has finally gone away
- has found a new friend
- is playing hide-and-seek
- is waiting for him at home

5 Owl feels sad when he gets home probably because he is

- angry
- lonely
- sick
- tired

- 6** The story says that the moon sailed after Owl. The word sailed makes the moon seem like a

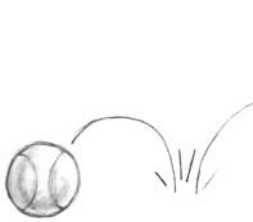

ball

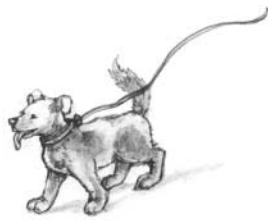

pet



ship



star

Directions For Numbers 7 and 8, choose the word or words that best complete each sentence.

- 7** The moon _____ over the sea.

have risen

are rising

were rising

has risen

- 8** Last night I _____ an owl by the light of the moon.

saw

see

sees

seeing

9 Find the sentence that best completes the story.

_____. First we swim.
Then we play in the sand.

- Looking for shells is easy to do.
- In summer, we like to go to the beach.
- My sister is a good tennis player.
- The weather is usually warmer in summer.

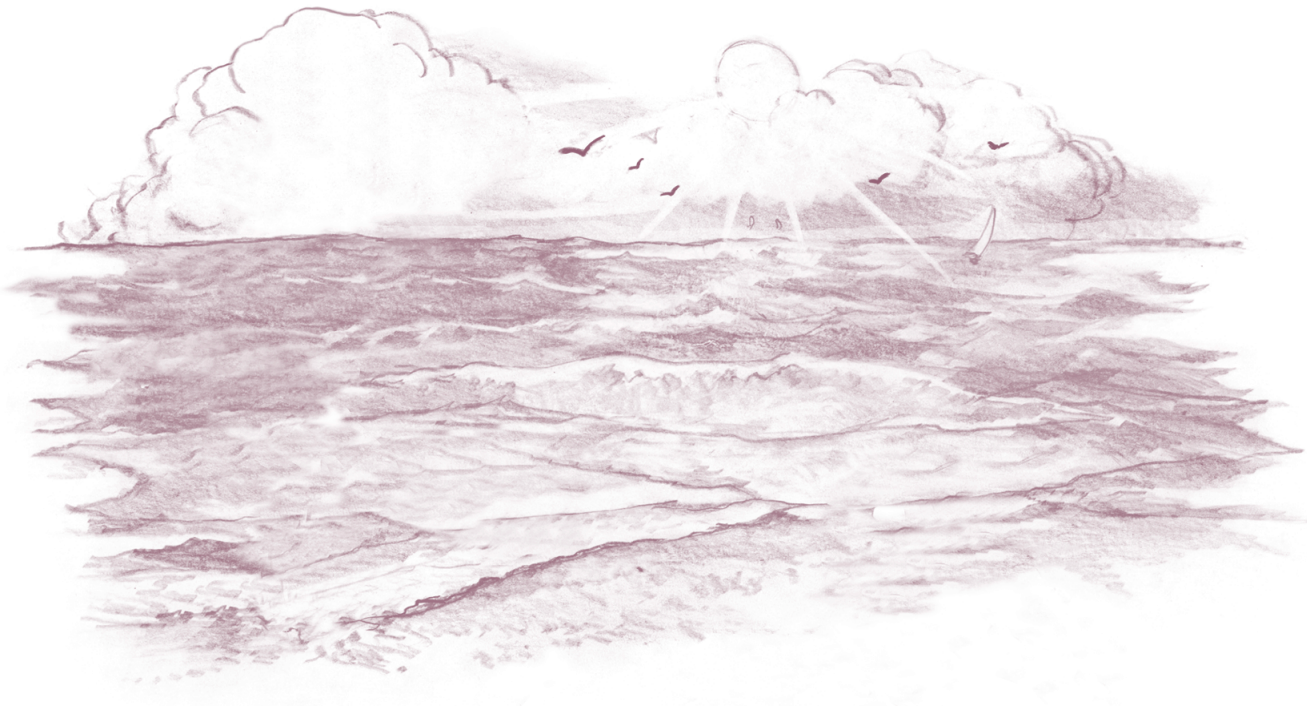

- 10** Look at the web showing how Owl felt in different parts of the story. In the empty box, write a word that tells how Owl felt at the end of the story.

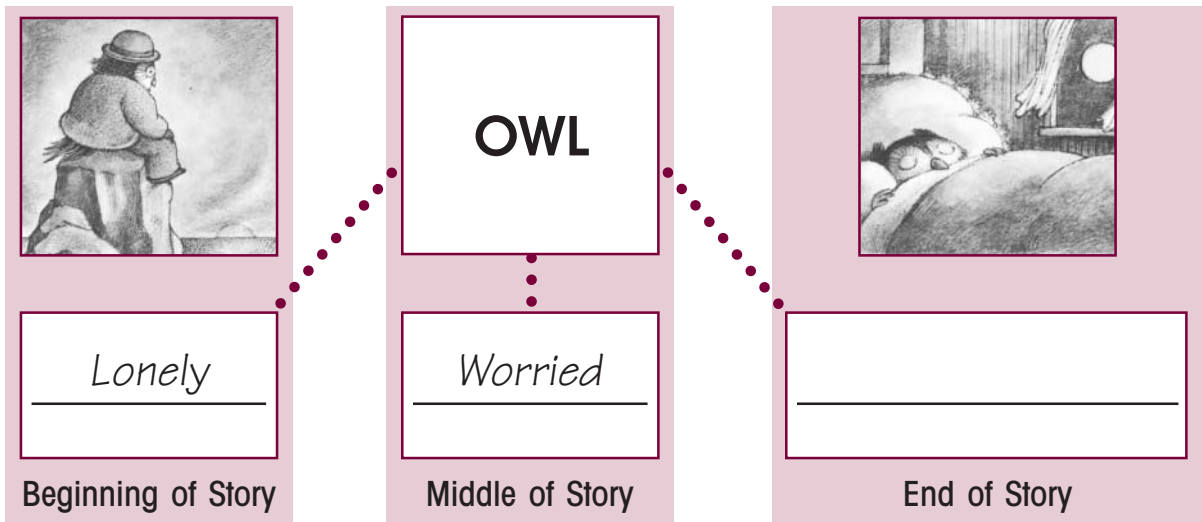

Now write a sentence telling why Owl felt that way at the end of the story.



Be sure to use the correct capitalization and punctuation for your sentence.

Directions

Read this story about Eve Bunting, who is the author of many children's books. Then answer Numbers 11 through 19.



Once Upon a Time

by Eve Bunting

"Finn MacCool, the Irish giant, was the only giant in all of Ireland."

That was the first sentence in my first book.

I think I wrote that story because I love giants . . . and I love Ireland.

That's where I was born, in this house in a little town called Maghera.

My father had been born in this same house, and my Grandfather Bolton before that.

Way back it had been a granary where farmers stored grain.



Sometimes, when we sat in the kitchen there'd be a creak as the old house settled.

A small shower of seeds would drop down on us.

I always thought there was someone up there playing tricks on us, and I'd say, "You up there! Stop that!"

I went to boarding school in Belfast, Ireland, when I was seven years old. There were twelve girls in the dormitory where I slept. After "lights out" we loved to tell stories, especially scary ones. . . .

When I went home from school for the holidays I read a lot.

That was partly because it rains so much in Ireland.

The rain is what makes it so pretty and green.

My parents read to me, too.

Mostly my father read poetry out loud.

Poetry was his favorite.

"It was the schooner Hesperus,

That sailed the wintry sea;

And the skipper had taken his little daughter,

To bear him company," he'd read.

I'd know something terrible was coming in the poem and I'd hide my face against his shoulder.

On sunny days we often went to the beach.

Here I am with my father on Portstewart Strand.

See my funny little cap? I was just getting over mumps and was keeping warm. We are both rather dressed up.

I think he'd taken me for "a breath of fresh air."

I'm sure there were books in our Austin car. I don't remember, but I'm sure it rained some time that day. And I'm sure we sat in the car and read to each other till the clouds passed.

When I grew up and got married I was lucky. My new husband Ed loved books too.



11 This story is mostly about Eve Bunting's

- family and friends in Belfast
- experiences at school
- books on the history of Ireland
- childhood and love of books

12 What was author Eve Bunting's first book about?

- an Irish giant
- schools in Ireland
- the town of Maghera
- her grandfather's house

13 Find the picture that best shows what the girls did after “lights out.”



○



○

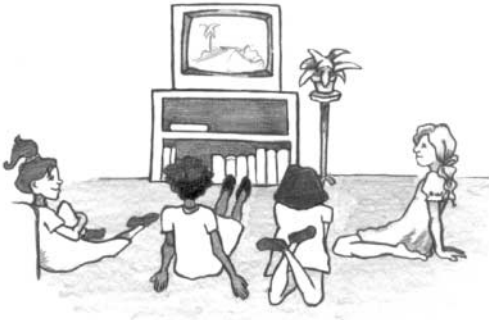

○



○

14 How did rain help Eve become a good reader?

- There are lots of good stories written about rain.
- Rain makes the countryside green and beautiful.
- It always rained when they went to the beach.
- Reading is a good indoor activity when it's raining.

15 Why does the author say she was lucky to marry her husband Ed?

- He had a kind face.
- He loved to read, too.
- He lived in Ireland, too.
- He enjoyed hearing scary stories.

16 Find the word that best completes the sentence.

What happens in real life can often be _____ than what we read in stories.

- strange
- stranger
- strangest
- strangely

17 Find the sentence that is complete and written correctly.

- Long before radio and television.
- Tales of heroes and brave deeds.
- Storytellers went from village to village.
- Along with the music of harp and drums.

18 Choose the best topic sentence for the paragraph.

_____. It was given that name because the Irish countryside is covered with rich shades of green. The island looks like a bright green jewel sparkling in the sea.

- Ireland is often called the Emerald Isle.
- Ireland is an island in the Atlantic Ocean.
- Ireland is the country where Eve Bunting was born.
- Ireland is known for the beauty of its lakes and rivers.

19 Here is part of a letter that a student wrote to Eve Bunting. There are three mistakes. Draw a line through each part that has a mistake, and write the correction above it.

Our teacher said us could read any book we wanted. I chose your book about the grandmother who learned to read, her hard work made her whole family happy.

Directions

Read this chapter from a book by Barbara Shook Hazen.
Then answer Numbers 20 through 30.

Trial Run

from *Amelia's Flying Machine*

At one time, Amelia Earhart was probably the most famous pilot in the world. Even as a child, she sometimes did things that could be dangerous. One summer, she and her sister Muriel and their cousins Katherine and Lucy built a roller coaster from old boards. Jimmy, a neighbor, came to watch.

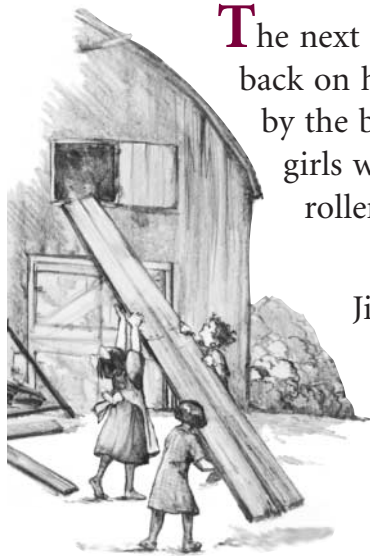

The next day Jimmy came back on his bicycle. He rode by the barn just as the girls were setting up the roller coaster.

“Not bad,” said Jimmy when he saw it. “Not bad at all, for girls.”

“What does that mean?” asked Amelia, tossing her head.

“Nothing much,” said Jimmy. Then he asked, “Does it work? That’s what I want to see.”

“You will,” said Amelia. “Just wait.”

Jimmy leaned his bike against a tree. He sat down on the grass and watched. “Who’s going to go first?” he asked.

Amelia scooped up some pieces of straw. She broke off three short bits and one long one.

Then she turned to the others. “We could draw straws. That would be fairest.”

“No thanks,” said Katherine. “Not me. You go first, Amelia.”

“Yes, you first,” said Lucy. “It was all your idea.”

Muriel looked up at the track slanting out of the hayloft window and shuddered. “Not me, Meeley,” she said. “It looks awfully high.”

“See,” said Jimmy smugly. “Your sister is scared. Your cousins are scared of things like roly coasters. Girls are always scared of things like roly coasters.”

Amelia faced Jimmy squarely. “Is that so?” she said. “Well, I’m a girl, and I’m not scared. I’ll gladly go first!”

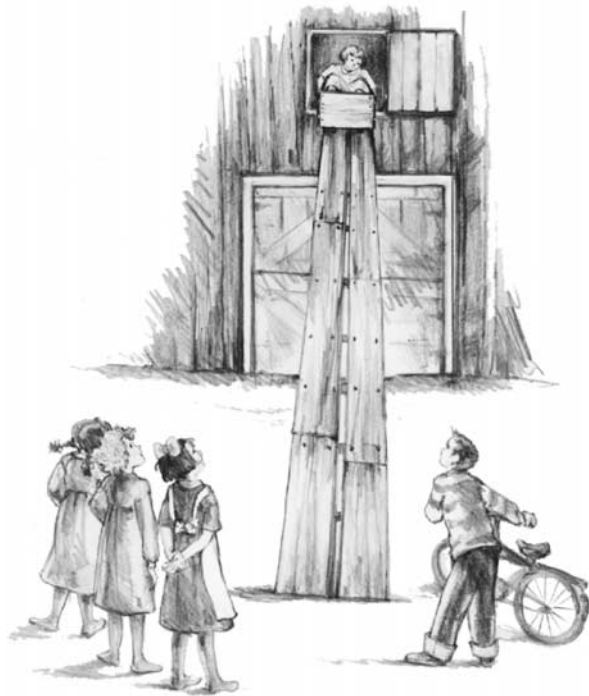

Amelia tested the track to make sure it was firmly set on the ground. Then she picked up the roller coaster car and carried it into the barn. She carried it up the ladder to the hayloft and placed it on the wooden track. And then she squeezed herself inside the car. It *was* a tight fit.

She pushed herself part way out the barn window. She held on tight to the track sides and looked out. It was a long way down.

“What are you waiting for?” Jimmy called. “Are you scared?”

“Nope, not a bit!” said Amelia, letting go of the track sides.

The orange-crate car started to roll. It went faster and faster down the track.

Amelia hugged her knees and held on tight. “Whee!” she cried. “I’m flying!”

The car gathered speed as it raced down the track and hit the ground with a hard bump.

It landed so hard that it flipped over. Amelia flew out and fell on the ground. She lay on her stomach moaning, “Ooooooooooooooh!”

Katherine and Lucy and Muriel raced to her.

“I told you so,” scolded Katherine. “You should have listened, but you never do.”

“Are you hurt?” asked Lucy, trying to see Amelia’s face.

Muriel just sobbed, “Oh, Meeley!”

Even Jimmy looked worried. He held out a hand to help Amelia up. “Are you okay?” he asked hesitantly.



“Sure. I’m okay,” Amelia gasped. She turned herself over and brushed the dirt off her dress.

Then she sat up and folded her arms. Her expression was stubborn. “I’m okay, all right,” she said. “But the track isn’t. I made a stupid mistake.”

Amelia paused. Then she frowned. “What’s wrong is that the track is too short,” she said. “That makes the slant too steep. And that’s why the car hit the ground so hard.

“What we have to do,” she said, getting up, “is add more boards and make the track longer.”

“Why don’t you just call it quits, huh?” suggested Jimmy.

“Not now!” said Amelia. “Not when I know what went wrong.” She looked at Jimmy. “Come back this afternoon. You’ll see how well it works.”

Jimmy walked toward his bike. “You sure are one nutty girl,” he muttered.



20 Amelia can best be described as

- lonely
- helpful
- daring
- relaxed

21 Which of these lines from the chapter best supports your answer for Number 20?

- “Well, I’m a girl, and I’m not scared. I’ll gladly go first!”
- “Your cousins are scared of things like roly coasters.”
- “Are you hurt?” asked Lucy, trying to see Amelia’s face.
- “What does that mean?” asked Amelia, tossing her head.

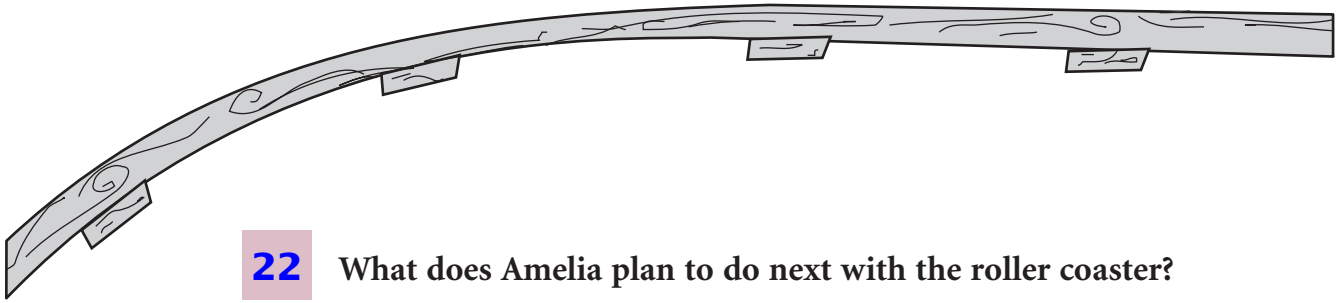

22 What does Amelia plan to do next with the roller coaster?

- enter it in a contest
- build another car
- build a longer track
- start an amusement park

23 Amelia's reaction to the experience told about in this chapter shows that

- she can learn from her mistakes
- she only cared about having fun
- she will grow up to be a famous pilot
- she had less freedom than girls have today

24 The author probably wrote "Trial Run" to show

- what a famous person was like as a child
- what you need to build a roller coaster
- that girls and boys can play together
- that children must work hard on a farm

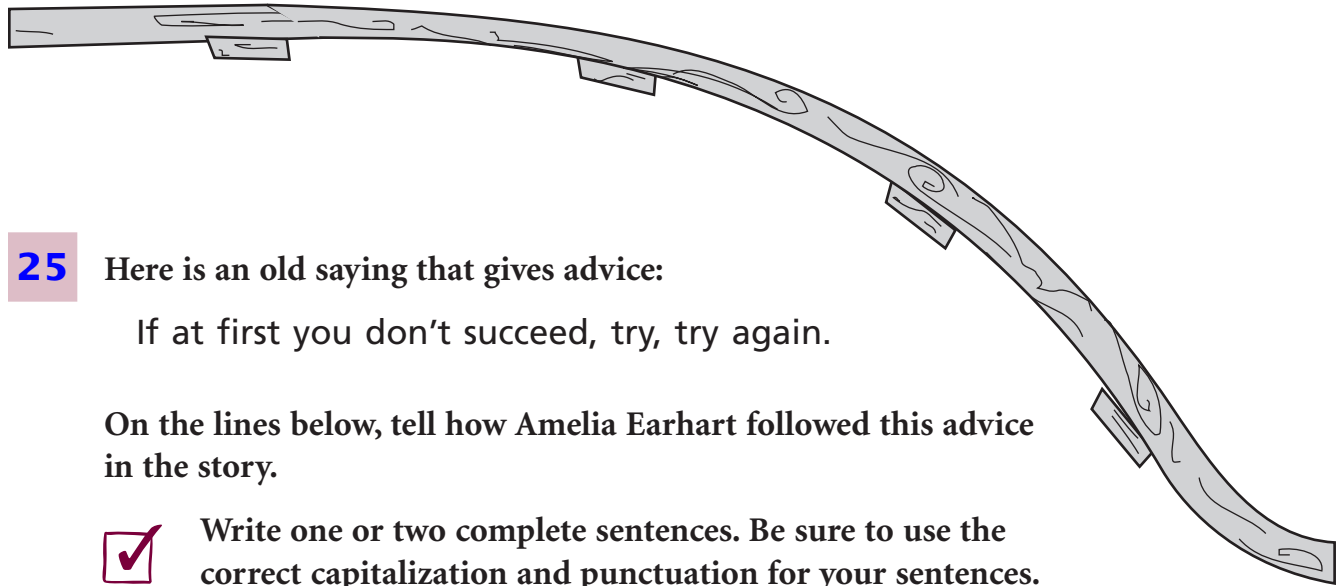

25 Here is an old saying that gives advice:

If at first you don't succeed, try, try again.

On the lines below, tell how Amelia Earhart followed this advice in the story.



Write one or two complete sentences. Be sure to use the correct capitalization and punctuation for your sentences.

26 Find the word that has the prefix, and only the prefix, underlined.

repair

today

disappear

unroll

27 Choose the word that best completes both sentences.

We made hats out of ribbons and _____.

Chris _____ better after he rested.

- paper
- looked
- felt
- seemed

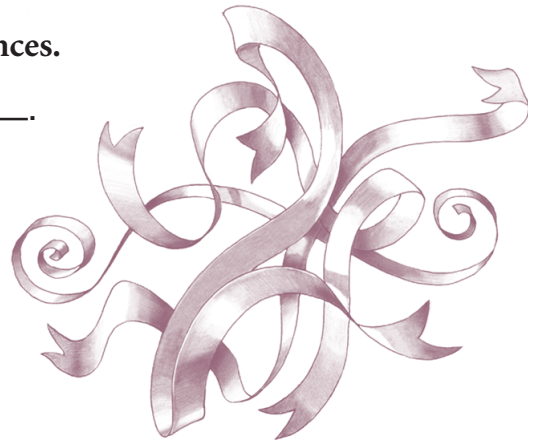

28 Find the sentence that has the correct punctuation.

- How's Patrick getting home?
- Its raining hard today.
- Why couldnt' you play with me?
- We did'nt want to eat a snack.

- 29** Find the part of the sentence that needs to be changed.
If no part needs to be changed, mark “None.”

I used to read | The cat in the Hat | almost every day. None

- 30** Find the phrase containing an underlined word that is not spelled correctly.
If all the underlined words are spelled correctly, mark “All correct.”

- enjoy a dessert
- point a finger
- spoyl a party
- All correct

Student Name _____

1

Look at the calendar below.

MAY						
Sunday	Monday	Tuesday	Wednesday	Thursday	Friday	Saturday
	1	2	3	4	5	6
7	8	9	10	11	12	13
14	15	16	17	18	19	20
21	22	23	24	25	26	27
28	29	30	31			

What day of the week is one day after May 23?

- Monday
- Tuesday
- Wednesday
- Thursday

2

Look at the thermometer.

What temperature does the thermometer show?

- 10 degrees
- 30 degrees
- 40 degrees
- 50 degrees

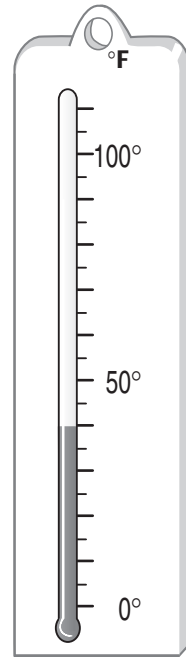
**3**

Look at the pattern below.



What shape should be next in the pattern?

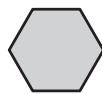

4

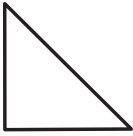

Which of these shapes is exactly the same size and shape as the triangle shown above?

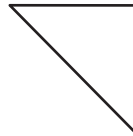
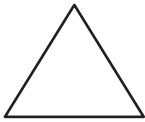

5

Which of these is shaped like a sphere?

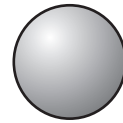
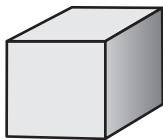

6

During the first hour of a carnival, 25 cups of lemonade were sold. Each cup cost \$0.50. Which of these shows a way to find how much money was earned during the first hour?

- $25 + \$0.50$
- $25 \times \$1.00$
- $\$0.50 + 1$
- $25 \times \$0.50$



7



This shape is a side of which solid shape below?

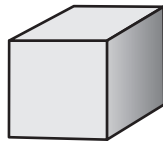
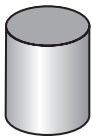

8

Carl can run 1 mile in 9 minutes. He always runs at the same speed. Which of these shows a way to find how long it would take him to run 3 miles?

- $9 + 3$
 - $9 - 3$
 - 9×3
 - $9 \div 3$
-

9

What is 1,729 rounded to the nearest thousand?

- 1,000
- 1,500
- 1,700
- 2,000

10

Look at the pizza below. The shaded part shows the part that Ben ate.

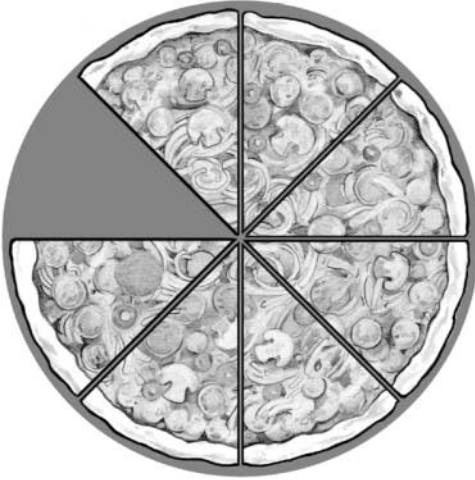

What fraction stands for the part of the pizza that Ben ate?

$\frac{1}{2}$

$\frac{1}{3}$

$\frac{1}{4}$

$\frac{1}{8}$

11

Donna spilled paint on this number line. How many whole numbers were covered with paint?

 5

 6

 7

 8

12 Solve this problem.

$$7 \times 6 =$$

- 13
 - 36
 - 42
 - 49
-

13 Carlos wants to buy the toys shown below.



\$1.25

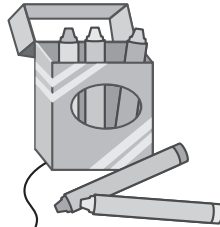

\$1.50

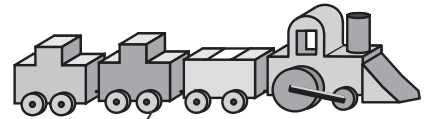

\$3.75

How much will the toys cost all together?

- \$5.50
- \$6.50
- \$7.00
- \$8.00

14

Out of 98 students who signed up for swimming class, 31 signed up for the guppy class. About how many students did not sign up for the guppy class?

- 30
 - 60
 - 70
 - 100
-





15

On Monday it took Mr. Green 10 minutes to drive 5 miles to the theater. On Tuesday he drove 10 miles to the park. If Mr. Green drove at the same speed both days, how long did it take him to drive to the park?

- 5 minutes
- 10 minutes
- 15 minutes
- 20 minutes

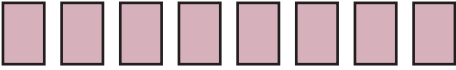

Mira's Stickers

Dinosaur stickers	
Horse stickers	
Dolphin stickers	
Bird stickers	
Cat stickers	

each  = 4 stickers

16 How many more bird stickers than cat stickers does Mira have?

- 3 4 12 16

17 Which of these is another way to show the correct number of dinosaur stickers?

Dinosaur stickers = 

stickers Dinosaur	number five
----------------------	----------------

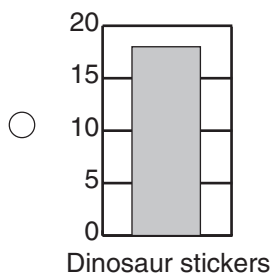

Dinosaur stickers = 16 stickers

18

Don is carrying 4 marbles in his pocket. His brother is carrying 3 times as many marbles as Don. How many marbles are Don and his brother carrying all together?

Show your work.

_____ marbles



19



Use the centimeter side of your ruler to help you solve this problem.

Carmen invented a new unit of measure called a “**bink**.” This marker is 2 binks long.

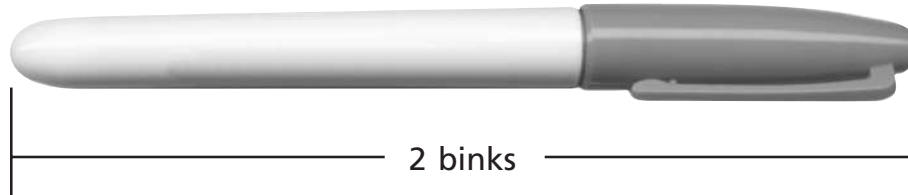

How many **centimeters** long is 1 bink? Write your answer on the line below.

1 bink = _____ centimeters

Carmen is measuring a toy train that is 10 binks long. How many **centimeters** long is the toy train? Write your answer on the line below.

The train is _____ centimeters long.

On the lines below, explain how you found your answer.

20

Sherri bought a pack of gum for 45¢. The pack contained 16 pieces of gum. She gave 2 pieces of gum to each of her friends.



What else is needed to find the number of pieces of gum Sherri had left?

What fact written in the box is not needed to find the number of pieces Sherri had left?

Student Name _____

- 1** The table below shows the number of eggs collected on a farm on three different days.



Days Eggs Collected	Number of Eggs Collected
Monday	25
Tuesday	15
Wednesday	30

Which of these bar graphs shows the information in the table?

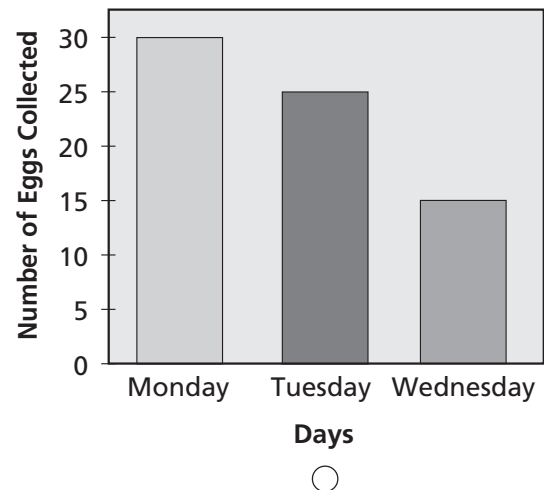
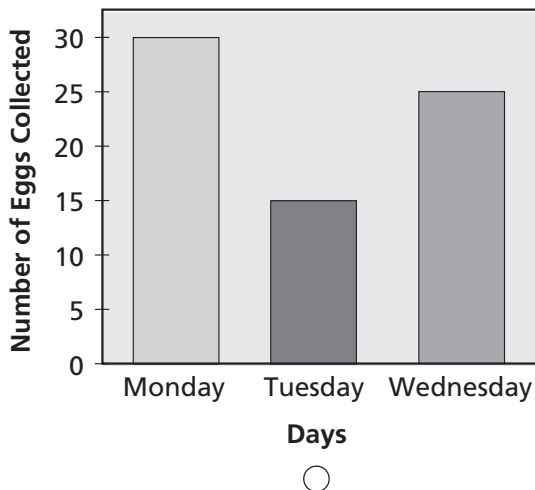
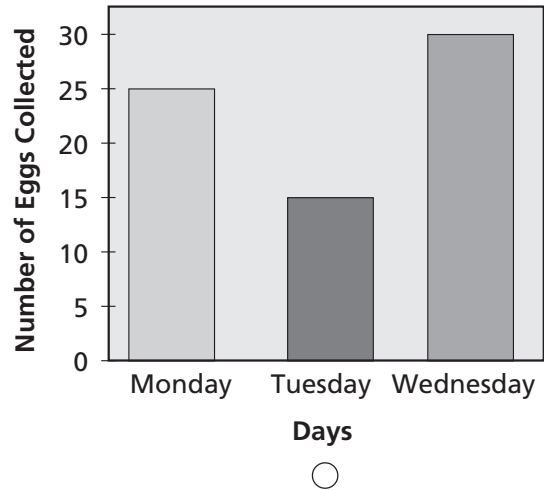
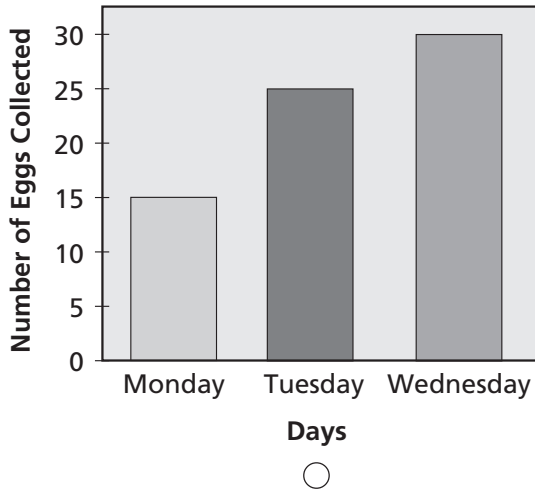

2 Which of these would you use to enter information into a computer?

- 1
- 2
- 3
- 4

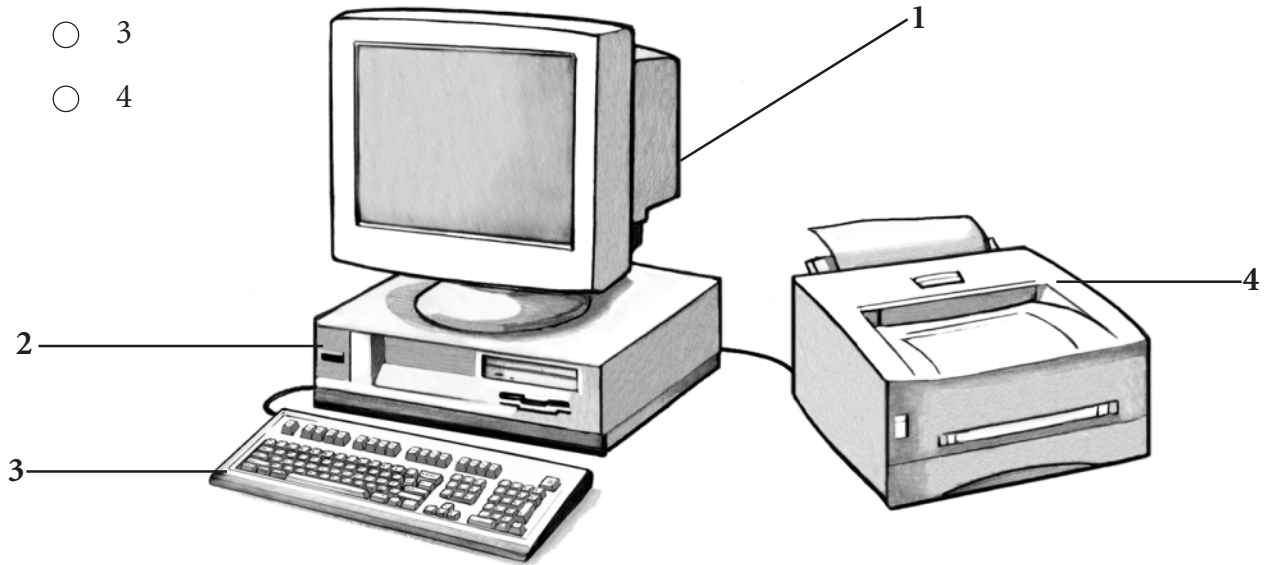

3 Which picture shows something that causes soil erosion?





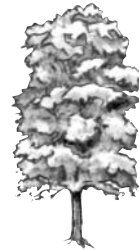



4 Which picture shows the part of the tree that takes in water?



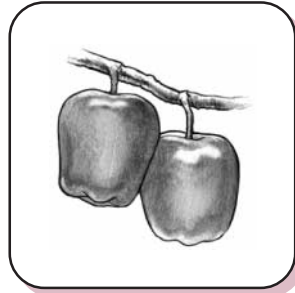

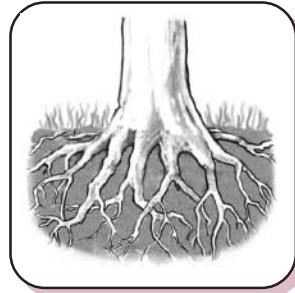



5 Which of these is a solid?

- air
- oil
- heat
- paper

6 Which of these is easiest to measure accurately?

- how funny a person is
- how happy a person is
- how tall a person is
- how wise a person is

7 Which of these usually makes static electricity?

- rubbing a magnet against a nail
- rubbing your hands together
- rubbing a balloon in your hair
- rubbing two sticks of wood together

8 The astronauts who visited the moon left footprints wherever they walked.

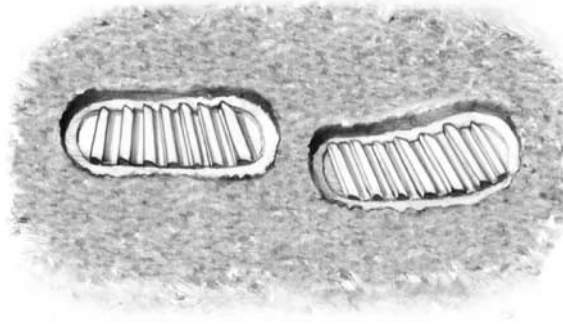

Why will those footprints probably stay on the moon's surface for a very long time?

- The moon's surface is very cold.
- The moon's gravity is very weak.
- They quickly harden on the moon.
- There is no air or wind on the moon.

9 Your teacher asks you to keep a record of how fast you are growing throughout the school year. How often should you measure your height?

- every day
- every other day
- twice a week
- once a month

10 Riding a bike to school is usually

- the fastest way to get there
- a way to reduce pollution
- the safest way to get there
- a way to avoid accidents

11 Which of these objects can conduct electricity?

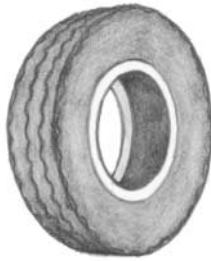

12 Which of these pairs of animals are most closely related?

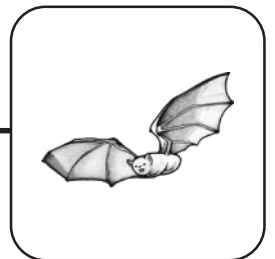
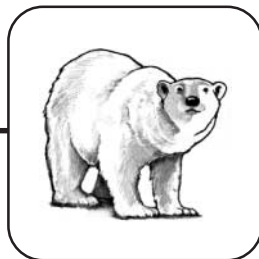
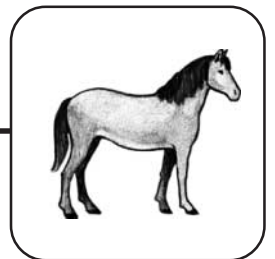
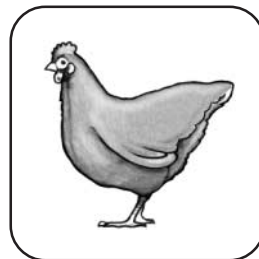
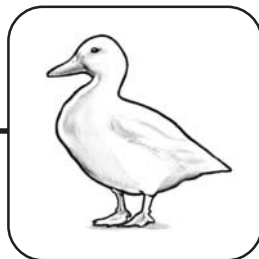

- 13** Each day at lunch time, Jackie recorded the air temperature and the number of snails in her garden.

Her record for five days is shown in the table below.



Day of the Week	Number of Snails	Temperature (in °F)
Monday	12	76
Tuesday	10	72
Wednesday	8	63
Thursday	7	61
Friday	5	45

What happens to the number of snails in Jackie's garden as the temperature goes down?

- 14** Look at the chart. Place an X in the box to show if the object is a solid or a liquid. The first one has been done for you.

	Solid	Liquid
pencil	X	
sugar		
oil		
wood		
water		

- 15** Your friend wants to find out if using more soil will help a plant grow bigger. For this experiment, your friend is using the three pots and plants shown below.

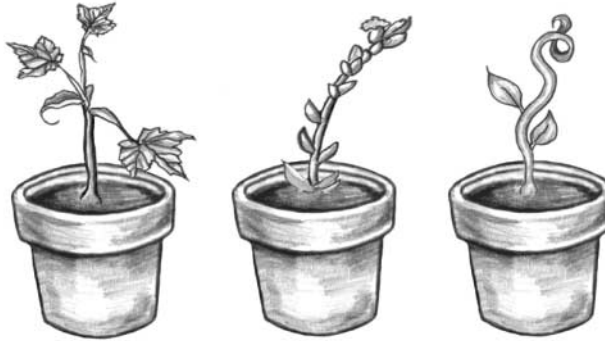

Describe two things your friend needs to change in order to improve the experiment.

one:

two:

Student Name _____

Some Products of the United States

Directions Use the map below and what you know to do Numbers 1 through 3.



KEY

- city
- cattle
- corn
- wheat
- forest products
- oranges
- potatoes
- sugar cane



Copyright © 2002 by CTB/McGraw-Hill LLC. This page may be reproduced for educational purposes only.

1 According to the map, which of these is found nearest Billings?

- corn
- cattle
- potatoes
- oranges

2 According to the map, near which of these cities is sugar cane grown?

- Hilo
- Boston
- Anchorage
- San Francisco

3 What does the map show about the United States?

- the names of the states
- the number of people who farm
- the way some land is used
- the population of some cities

United States Trade

Directions

Use the bar graph below and what you know to do Numbers 4 through 6.

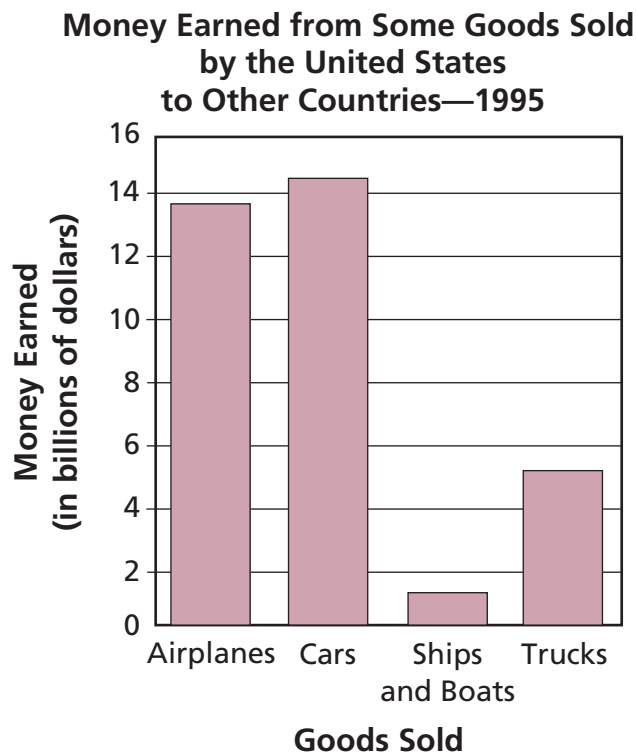

4 According to the graph, the most money was made from the sale of

- airplanes
- cars
- ships and boats
- trucks

5 The goods shown on the graph are

- farm tools
- natural resources
- building supplies
- types of transportation

6 Which of these goods earned about \$5 billion in sales?

- airplanes
- cars
- ships and boats
- trucks

United States History Time Line

Directions Use the time line below and what you know to do Numbers 7 through 10.

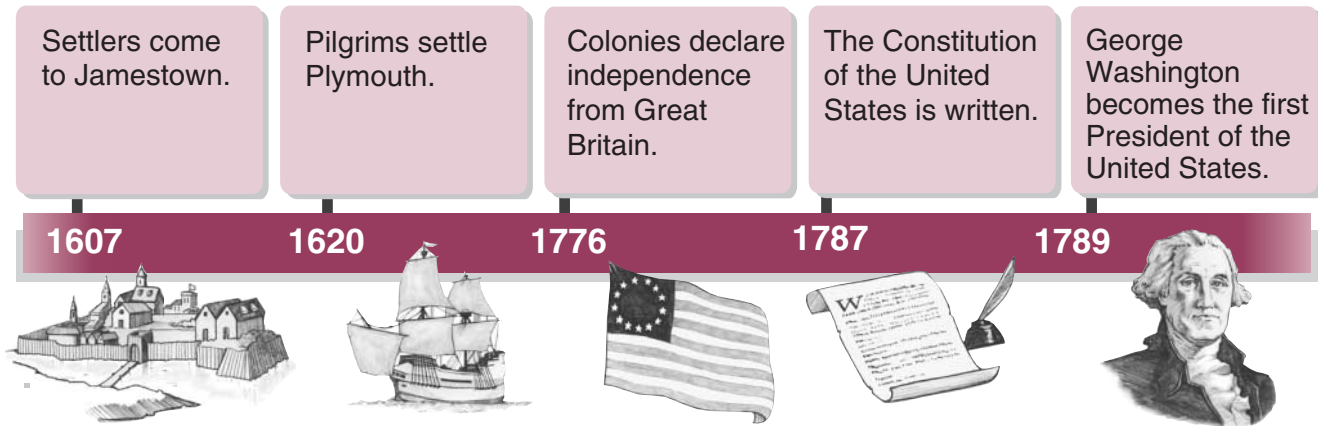

7 In which year did the Pilgrims settle Plymouth?

- 1607 1776
 1620 1787

8 Which of these events happened closest to our time?

- Settlers came to Jamestown.
 The colonies declared their independence.
 The Constitution of the United States was written.
 George Washington became the first President of the United States.

9 In which year did government leaders make a plan for how the government would work?

- 1620 1787
 1776 1789

10 Which of these can be learned from the time line?

- what life was like at Plymouth
 where the colonies were located
 who wrote the Constitution of the United States
 when the United States got its first president

Tax Money



Directions

Use the web below and what you know to do Numbers 11 and 12.

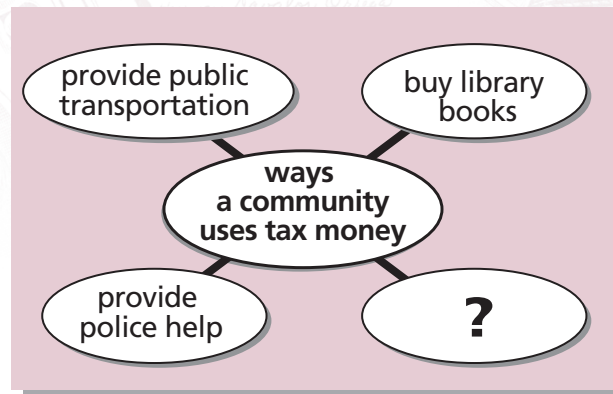

11 Which of these best completes the web above?

- fix roads
- operate a grocery store
- hire factory workers
- build a movie theater

12 Which of these workers is most likely paid with tax money?

- a farmer
- a firefighter
- a football player
- a restaurant owner

Transportation in Pine City Today

Directions The chart below gives information about some different types of transportation centers in Pine City. Use the chart to do Number 13.

Some Transportation Centers
in Pine City

Type of Center	Number of Centers
Bus Station	9
Subway Station	15
Train Station	3



13 Use the information in the chart above to complete the bar graph below.

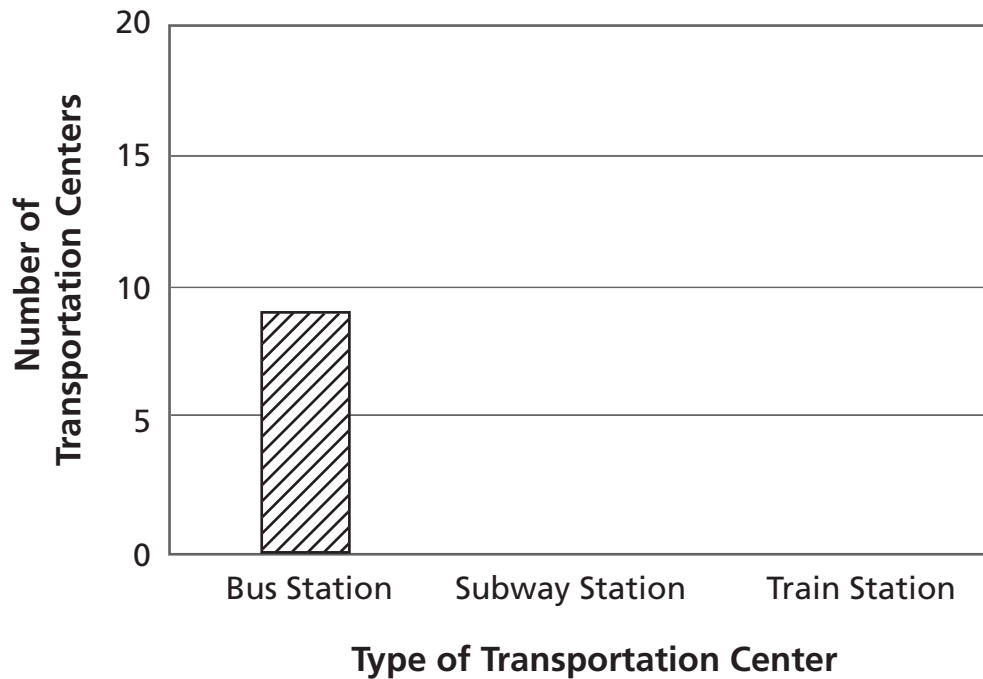

Let's Clean Up

On their way home from Grandmother's house, Carla and her father drove by the Pine River. Along the river they saw a lot of garbage, including paper, bottles, and cans.

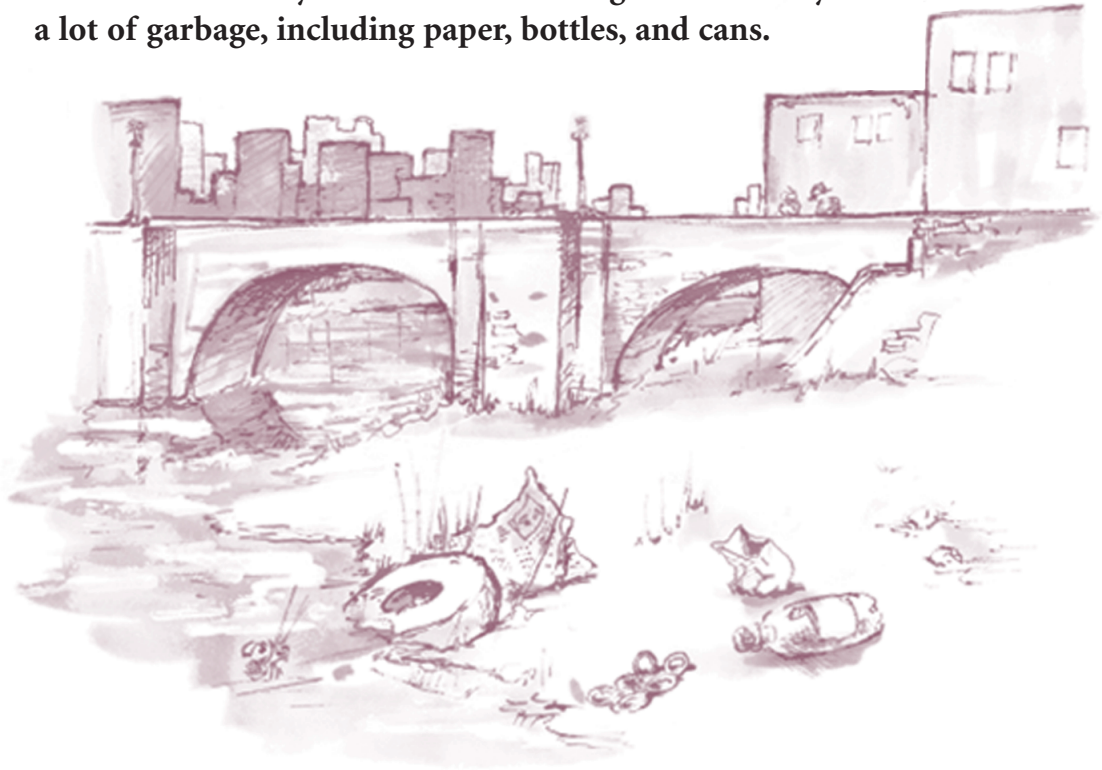

Directions Read the passage. Then do Number 14.

Carla and her father made some signs telling people about a meeting. They put the signs up in their neighborhood. At the meeting, people discussed how they could help to clean up the river area. The following Saturday, the neighborhood group went to the river and cleaned up the garbage.

- 14** These pictures show the steps Carla and her neighbors took to help clean up the river. Put the pictures in the order described in the passage by writing the numbers 1, 2, 3, or 4 in the circle on each picture.



The History Museum

Directions The pictures below show some objects that are in a history museum. Use the pictures and what you know to do Number 15.

Objects Used by Native American Indians Long Ago



turtle shell rattle



fish hook



wooden bowl



corn grinder



drum



bow and arrow

15 Complete the chart below by making groups of two objects that go together. Then tell how they were used. An example has been done for you.

- List two objects for Group 1 and two objects for Group 2.
- Then tell how each **group** of objects was used.

	Objects	How they were used
Example	1. wooden bowl 2. corn grinder	Both were used for preparing food.
Group 1	1. 2.	Both were used for _____ _____
Group 2	1. 2.	Both were used for _____ _____

Introduction

This section of Classroom Connections to *TerraNova, The Second Edition* includes answer keys and scoring guides for the Student Practice Materials found in [Parts 4](#) and [5](#). The answer key is divided by subject area and identifies the correct response and objective for each selected-response item. Objectives and rubrics for items identified as “Constructed Response” are found on the pages following the answer key.

The following graphic shows the Grade 2 Reading and Language Arts answer key. The letters in circles describe how each part of the answer key is used.

		Part 6 Scoring Guide—Grade 2 Answer Key						6.5	
Student Practice Materials Answer Key									
* Note: The objectives and rubrics for these items are found on the pages following the answer key.									
Reading and Language Arts									
A	1	C	02 Basic Understanding	12	B	02 Basic Understanding	23	C	09 Editing Skills
B	2	A	02 Basic Understanding	13	C	03 Analyze Text	24	A	09 Editing Skills
	3	B	02 Basic Understanding	14	B	05 Identify Reading Strategies	25	*	Constructed Response ← E
C	4	C	02 Basic Understanding	15	A	08 Writing Strategies	26	*	Constructed Response
	5	A	04 Evaluate and Extend Meaning	16	*	Constructed Response	27	B	32 Vowels (Word Analysis)
D	6	C	02 Basic Understanding	17	D	02 Basic Understanding	28	D	34 Roots and Affixes
	7	B	06 Introduction to Print	18	A	04 Evaluate and Extend Meaning	29	C	39 Writing Conventions
	8	B	09 Editing Skills	19	C	02 Basic Understanding	30	B	38 Sentences, Phrases, Clauses
	9	C	09 Editing Skills	20	D	03 Analyze Text	31	A	40 Vowels (Spelling)
	10	C	03 Analyze Text	21	B	02 Basic Understanding			
	11	A	02 Basic Understanding	22	D	07 Sentence Structure			

- A** The content area of the Student Practice Materials administered.
- B** The number of the item administered.
- C** The correct answer.
- D** The objective being measured.
- E** A constructed-response item. (The objective and rubric for this item are found on the pages following the answer key.)

How to Use the Scoring Guide for Reading and Language Arts

There are several constructed-response (CR) items in the Student Practice Materials. Each CR item has its own rubric (rules for scoring) used to evaluate a student's performance. The following graphic shows a sample rubric from a Reading and Language Arts CR item at Grade 3. The letters in circles describe how each part of the scoring guide is used.

Part 6 Scoring Guide—Grade 3 **6.19**

A → **Reading and Language Arts**

B → **Item 10 Student Practice Materials page 5.9**

C → **Objective 05: Identify Reading Strategies**

Rubric 2 points

- 1 point for writing a word suitably describing Owl at the end of the story
- 1 point for explaining why Owl felt that way (must be in terms of the word chosen and pertain to the end of the story)

D → **Objective 09: Editing Skills**

Rubric 3 points



- 1 point for writing at least one complete sentence
- 1 point for using correct initial capitalization
- 1 point for using the correct punctuation

Note:

- If the student wrote more than one sentence, score only the sentence with the fewest mistakes.

E → **Example of acceptable response:**

10 Look at the web showing how Owl felt in different parts of the story.
In the empty box, write a word that tells how Owl felt at the end of the story.

	OWL	
<i>Lonely</i>	...	<i>Happy</i>
Beginning of Story	Middle of Story	End of Story

Now write a sentence telling why Owl felt that way at the end of the story.

Be sure to use the correct capitalization and punctuation for your sentence.

Owl is happy because his friend the moon is looking in the window.

F → **Other acceptable responses:**

- Sleepy: Owl is sleepy because he walked home from the seashore.
- Sad: At the end of the story, Owl is sad because he thinks the moon has gone away.

- A** The content area of the Student Practice Materials you administered.
- B** The item that is being scored.
- C** The objective being measured. (This item is scored twice—once for Objective 05 and once for Objective 09. The objective is always listed above the corresponding rubric.)
- D** Number of score points. (The rubric tells you how to evaluate student performance and assign score points.)
- E** Example of acceptable response. (A sample student response is printed in color.)
- F** Other acceptable responses.

How to Use the Scoring Guide for Mathematics

There are several constructed-response (CR) items in the Student Practice Materials. Each CR item has its own rubric (rules for scoring) used to evaluate a student's performance. The following graphic shows a sample rubric from a Mathematics CR item at Grade 2. The letters in circles describe how each part of the scoring guide is used.

Part 6 Scoring Guide—Grade 2 6.9

A → **Mathematics**

B → **Item 18 Student Practice Materials page 4.36**

C → **Objective 10: Number and Number Relations**

D → **Rubric 2 points**

- 1 point for a combination of coins circled equaling 56¢
- 1 point for a valid process

Note

- Students receive 1 point for a correct process with an error in computation.

Examiner reads directions aloud to students.

E → **Example of acceptable response:**

18 Charlie bought a pen for 56¢. Look at the group of coins. Circle the coins that add up to 56¢.

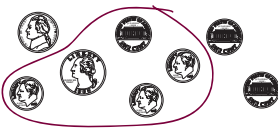

In the box below, add up the coins you circled to make 56¢.

$$\begin{array}{r} 25 \\ 10 \\ 10 \\ 10 \\ 10 \\ + 1 \\ \hline 56 \end{array}$$

F → **Other acceptable response:**

- Any other acceptable process

- A** The content area of the Student Practice Materials you administered.
- B** The item that is being scored.
- C** The objective being measured. (Item 18 measures Objective 10. The objective is always listed above the corresponding rubric.)
- D** Number of score points. (The rubric tells you how to evaluate student performance and assign score points.)
- E** Example of acceptable response. (A sample student response is printed in color.)
- F** Other acceptable responses.

Student Practice Materials Answer Key

★ Note: The objectives and rubrics for these items are found on the pages following the answer key.

Reading and Language Arts									
1	C	02 Basic Understanding	12	B	02 Basic Understanding	23	C	09 Editing Skills	
2	A	02 Basic Understanding	13	C	03 Analyze Text	24	A	09 Editing Skills	
3	B	02 Basic Understanding	14	B	05 Identify Reading Strategies	25	★	Constructed Response	
4	C	02 Basic Understanding	15	A	08 Writing Strategies	26	★	Constructed Response	
5	A	04 Evaluate and Extend Meaning	16	★	Constructed Response	27	B	32 Vowels (Word Analysis)	
6	C	02 Basic Understanding	17	D	02 Basic Understanding	28	D	34 Roots and Affixes	
7	B	06 Introduction to Print	18	A	04 Evaluate and Extend Meaning	29	C	39 Writing Conventions	
8	B	09 Editing Skills	19	C	02 Basic Understanding	30	B	38 Sentences, Phrases, Clauses	
9	C	09 Editing Skills	20	D	03 Analyze Text	31	A	40 Vowels (Spelling)	
10	C	03 Analyze Text	21	B	02 Basic Understanding				
11	A	02 Basic Understanding	22	D	07 Sentence Structure				
Mathematics									
1	C	14 Geometry and Spatial Sense	8	B	12 Operation Concepts	15	A	15 Data Analysis, Statistics, and Probability	
2	B	10 Number and Number Relations	9	D	12 Operation Concepts	16	B	15 Data Analysis, Statistics, and Probability	
3	D	10 Number and Number Relations	10	C	13 Measurement	17	B	15 Data Analysis, Statistics, and Probability	
4	D	10 Number and Number Relations	11	C	11 Computation and Numerical Estimation	18	★	Constructed Response	
5	A	11 Computation and Numerical Estimation	12	B	17 Problem Solving and Reasoning	19	★	Constructed Response	
6	B	16 Patterns, Functions, Algebra	13	B	13 Measurement	20	★	Constructed Response	
7	C	11 Computation and Numerical Estimation	14	A	16 Patterns, Functions, Algebra				
Science									
1	D	23 Science and Technology	6	D	20 Physical Science	11	B	21 Life Science	
2	B	23 Science and Technology	7	B	20 Physical Science	12	D	19 Science Inquiry	
3	A	19 Science Inquiry	8	A	22 Earth and Space Science	13	★	Constructed Response	
4	B	19 Science Inquiry	9	B	20 Physical Science	14	★	Constructed Response	
5	D	21 Life Science	10	C	22 Earth and Space Science	15	★	Constructed Response	
Social Studies									
1	A	28 Civics and Government Perspectives	6	A	29 Economic Perspectives	10	C	26 Geographic Perspectives	
2	C	28 Civics and Government Perspectives	7	C	27 Historical and Cultural Perspectives	11	B	29 Economic Perspectives	
3	B	26 Geographic Perspectives	8	D	27 Historical and Cultural Perspectives	12	D	28 Civics and Government Perspectives	
4	B	29 Economic Perspectives	9	A	28 Civics and Government Perspectives	13	★	Constructed Response	
5	B	29 Economic Perspectives				14	★	Constructed Response	
						15	★	Constructed Response	

Reading and Language Arts

Item 16 Student Practice Materials page 4.14

Objective 05: Identify Reading Strategies

Rubric 2 points

- 1 point for writing that Harry bit the piano leg (or nearly bit the lady's leg) in the first empty box
- 1 point for writing that Harry wagged his tail

Examiner reads directions aloud to students.

Example of acceptable response:

Directions For Number 16, you will write your own answers.

- 16** Here are some of the things that happened in the story about Harry and the lady. Fill in the two empty boxes by writing what Harry did in that part of the story. You may look back at the story.

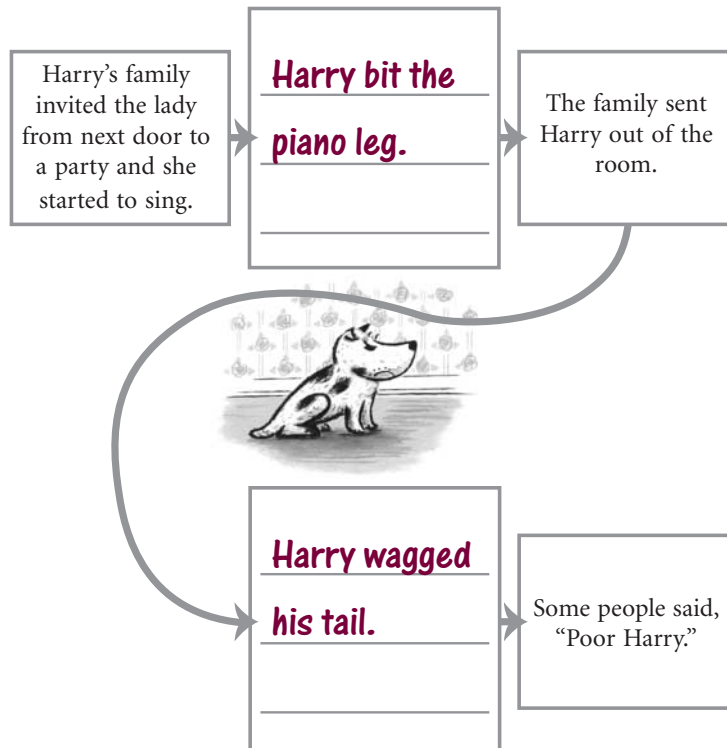

Other acceptable response:

[First Box]

- Harry nearly bit the lady's leg.

Reading and Language Arts

Item 25 Student Practice Materials page 4.20

Objective 02: Basic Understanding

Rubric 2 points

2 points for bee after dancing, parrot after squawking, dolphin after clicking (all three must be correct)

1 point for one or two responses correct

0 points for no responses correct

Examiner reads directions aloud to students.

Example of acceptable response:

- 25** Look in the box for the names of animals you have read about in
Do Animals Talk to Each Other?

Use the names to answer the questions below.
 You may look back at the story.



Which animal talks by dancing? honey bee

Which animal talks by squawking? parrot

Which animal talks by clicking? dolphin

Reading and Language Arts

Item 26 Student Practice Materials page 4.21

Objective 04: Evaluate and Extend Meaning

Rubric 1 point

- 1 point for stating the way an animal communicates

Note

- Depending on the quality of the explanation, the choice of any animal may be acceptable for credit.

Objective 07: Sentence Structure

Rubric 3 points

- 1 point for writing at least one complete sentence
- 1 point for using correct initial capitalization
- 1 point for using the correct punctuation

Note

- If the student wrote more than one sentence, score only the sentence with the fewest mistakes.

Examiner reads directions aloud to students.

Example of acceptable response:

- 26** Choose the animal whose way of talking is most like the way people talk to each other. Write the animal's name on the line below.

dolphins

Now write a sentence telling why you think this animal's way of talking is most like the way people talk to each other. Be sure to use capital letters when needed and the correct end mark.

Dolphins use clicks and whines the way

people use words.

Other acceptable responses:

- Parrots copy words that people say.
- Prairie dogs and people both kiss to say hello.

Mathematics

Item 18 Student Practice Materials page 4.36

Objective 10: Number and Number Relations

Rubric 2 points

- 1 point for a combination of coins circled equaling 56¢
- 1 point for a valid process

Note

- Students receive 1 point for a correct process with an error in computation.

Examiner reads directions aloud to students.

Example of acceptable response:

- 18** Charlie bought a pen for 56¢. Look at the group of coins. Circle the coins that add up to 56¢.



In the box below, add up the coins you circled to make 56¢.

25
10
10
10
+ 1
56

Other acceptable response:

- Any other acceptable process

Mathematics**Item 19 Student Practice Materials page 4.36****Objective 14: Geometry and Spatial Sense****Rubric 2 points**

- 1 point for one line drawn correctly
- 1 additional point for both lines drawn correctly

Examiner reads directions aloud to students.

Example of acceptable response:

19 Look at the rectangle below.

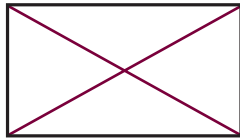

Draw 2 lines on the rectangle to divide it into 4 triangles.

Mathematics

Item 20 Student Practice Materials page 4.37

Objective 11: Computation and Numerical Estimation

Objective 17: Problem Solving and Reasoning

Rubric 2 points

- 1 point for 4 erasers
- 1 point for 12 erasers

Note

- If answer to second question is correct based on incorrect answer to first question, award 1 point.

Examiner reads directions aloud to students.

Example of acceptable response:

- 20** Erin bought a box of erasers. Then she bought 3 more erasers. She now has 7 erasers all together.

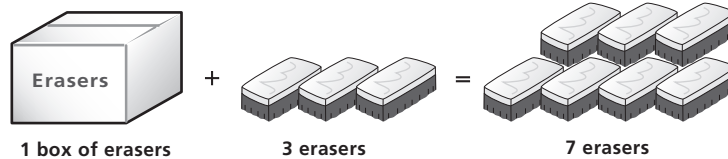

How many erasers are in the box? 4 erasers



How many erasers are in 3 boxes? 12 erasers

Science**Item 13 Student Practice Materials page 4.45****Objective 20: Physical Science****Rubric 3 points**

- 1 point for **P** written under paper bag
- 1 point for **W** written under bench
- 1 point for **R** written under tire

Examiner reads directions aloud to students.

Look at the pictures. Write a **P** on the line under the thing that is made of paper. Write a **W** on the line under the thing that is made of wood. Write an **R** on the line under the thing that is made of rubber.

Example of acceptable response:

13

**P**



**W**



**R**

Science

Item 14 Student Practice Materials page 4.46

Objective 21: Life Science

Rubric 1 point

- 1 point for circles drawn around ear, nose, and eye

Note

- All three parts must be circled in order to receive one point.
- 0 points if additional circles are drawn around the tail or the teeth.

Examiner reads directions aloud to students.

Look at the picture of the rabbit. Now look at the other pictures. Circle the parts of the rabbit that help it know it may be in danger.

Example of acceptable response:

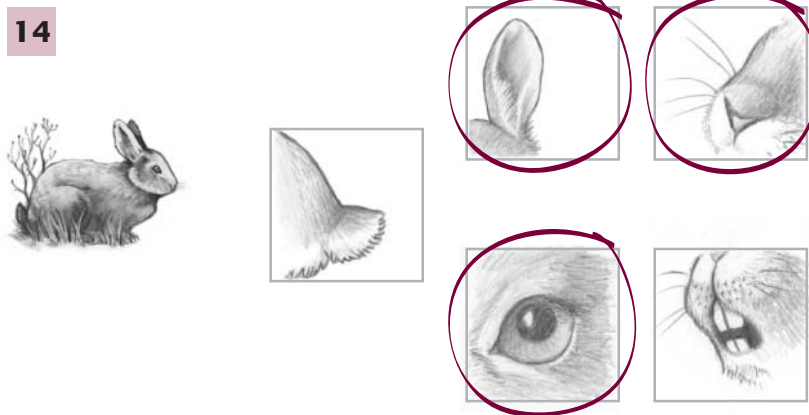

Science

Item 15 Student Practice Materials page 4.46

Objective 19: Science Inquiry

Rubric 1 point

- 1 point for circles drawn around beaker, thermometer, and measuring spoons

Note

- All three tools must be circled in order to receive one point.
- 0 points if additional circles are drawn around ruler, timer, or scale.

Examiner reads directions aloud to students.

You want to do an experiment to find out if adding a tablespoon of baking soda to a cup of vinegar changes the temperature of the vinegar. Look at the pictures. Circle the things that would help you do this experiment.

Example of acceptable response:

15

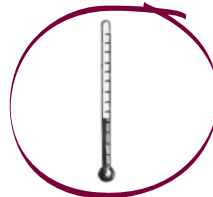
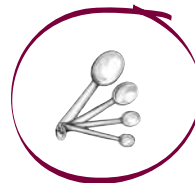
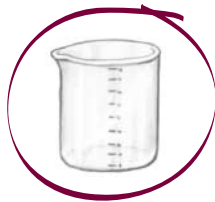

Social Studies

Item 13 Student Practice Materials page 4.54

Objective 27: Historical and Cultural Perspectives

Rubric 3 points

3 points for 2 examples of ways the city has stayed the same **AND** 2 examples of ways the city has changed (4 examples total)

2 points for 3 examples

1 point for 1 or 2 examples total

Note

- Do not give credit for responses that show how the people of the city have changed or stayed the same (e.g., “Long ago, people wore different clothes.”).

Examiner reads directions aloud to students.

Example of acceptable response:

13 Write two ways that the pictures show how the city has stayed the same over time.

- There are still people living in the city.
- There is still a fountain.

Now write two ways that the pictures show how the city has changed over time.

- There are more buildings in the city now.
- More people are living in the city now.

Other acceptable responses:

- any other response that shows how the city has stayed the same over time
- any other response that shows how the city has changed over time

Social Studies

Item 14 Student Practice Materials page 4.55

Objective 28: Civics and Government Perspectives

Rubric 2 points

- 1 point for **each** bar drawn correctly

Note

- Acceptable range is indicated by dotted line.
- Give full credit for correctly drawn bar with any sort of shading.
- Line graphs are not acceptable for credit.

Examiner reads directions aloud to students.

Example of acceptable response:

- 14** Use the chart to complete the bar graph.

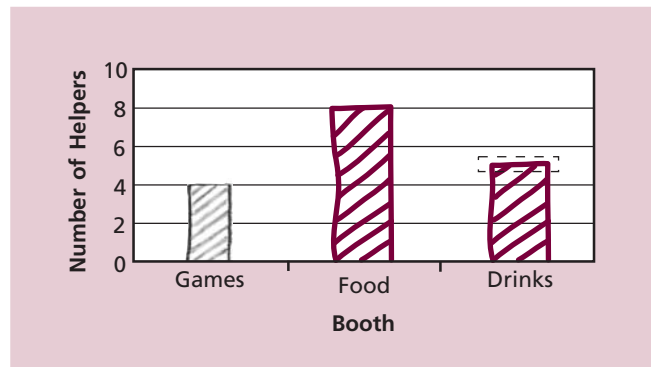

Social Studies

Item 15 Student Practice Materials page 4.56

Objective 27: Historical and Cultural Perspectives

Rubric 1 point

- 1 point for explaining that American independence is celebrated on the 4th of July

Note

- Give no credit for responses such as “We won the war.”

Examiner reads directions aloud to students.

Example of acceptable response:

15 What do people in the United States celebrate on the 4th of July?

It is Independence Day.

Other acceptable responses:

- It is the day the United States declared its independence from England.
- It is the day the United States became an independent/free country.
- It is the day the United States signed the Declaration of Independence.

Student Practice Materials Answer Key

★ Note: The objectives and rubrics for these items are found on the pages following the answer key.

Reading and Language Arts								
1	D	02 Basic Understanding	11	D	03 Analyze Text	21	A	05 Identify Reading Strategies
2	B	03 Analyze Text	12	A	02 Basic Understanding	22	C	02 Basic Understanding
3	D	02 Basic Understanding	13	A	05 Identify Reading Strategies	23	A	03 Analyze Text
4	A	04 Evaluate and Extend Meaning	14	D	04 Evaluate and Extend Meaning	24	A	04 Evaluate and Extend Meaning
5	B	03 Analyze Text	15	B	02 Basic Understanding	25	★	Constructed Response
6	C	04 Evaluate and Extend Meaning	16	B	09 Editing Skills	26	D	34 Roots and Affixes
7	D	09 Editing Skills	17	C	07 Sentence Structure	27	C	36 Multimeaning Words
8	A	09 Editing Skills	18	A	08 Writing Strategies	28	A	39 Writing Conventions
9	B	08 Writing Strategies	19	★	Constructed Response	29	B	39 Writing Conventions
10	★	Constructed Response	20	C	03 Analyze Text	30	C	40 Vowels (Spelling)
Mathematics								
1	C	13 Measurement	9	D	10 Number and Number Relations	15	D	17 Problem Solving and Reasoning
2	C	13 Measurement	10	D	10 Number and Number Relations	16	C	15 Data Analysis, Statistics, and Probability
3	B	16 Patterns, Functions, Algebra	11	A	10 Number and Number Relations	17	A	15 Data Analysis, Statistics, and Probability
4	C	14 Geometry and Spatial Sense	12	C	11 Computation and Numerical Estimation	18	★	Constructed Response
5	D	14 Geometry and Spatial Sense	13	B	11 Computation and Numerical Estimation	19	★	Constructed Response
6	D	12 Operation Concepts	14	C	11 Computation and Numerical Estimation	20	★	Constructed Response
7	B	14 Geometry and Spatial Sense						
8	C	12 Operation Concepts						
Science								
1	C	19 Science Inquiry	6	C	19 Science Inquiry	11	D	20 Physical Science
2	C	23 Science and Technology	7	C	20 Physical Science	12	B	21 Life Science
3	A	22 Earth and Space Science	8	D	22 Earth and Space Science	13	★	Constructed Response
4	C	21 Life Science	9	D	19 Science Inquiry	14	★	Constructed Response
5	D	20 Physical Science	10	B	24 Personal and Social Perspectives in Science	15	★	Constructed Response
Social Studies								
1	B	26 Geographic Perspectives	7	B	27 Historical and Cultural Perspectives	11	A	28 Civics and Government Perspectives
2	A	26 Geographic Perspectives	8	D	27 Historical and Cultural Perspectives	12	B	28 Civics and Government Perspectives
3	C	26 Geographic Perspectives	9	C	28 Civics and Government Perspectives	13	★	Constructed Response
4	B	29 Economic Perspectives	10	D	27 Historical and Cultural Perspectives	14	★	Constructed Response
5	D	29 Economic Perspectives				15	★	Constructed Response
6	D	29 Economic Perspectives						

Reading and Language Arts

Item 10 Student Practice Materials page 5.9

Objective 05: Identify Reading Strategies

Rubric 2 points

- 1 point for writing a word suitably describing Owl at the end of the story
- 1 point for explaining why Owl felt that way (must be in terms of the word chosen and pertain to the end of the story)

Objective 09: Editing Skills

Rubric 3 points

- 1 point for writing at least one complete sentence
- 1 point for using correct initial capitalization
- 1 point for using the correct punctuation

Note

- If the student wrote more than one sentence, score only the sentence with the fewest mistakes.

Example of acceptable response:

- 10** Look at the web showing how Owl felt in different parts of the story.
In the empty box, write a word that tells how Owl felt at the end of the story.

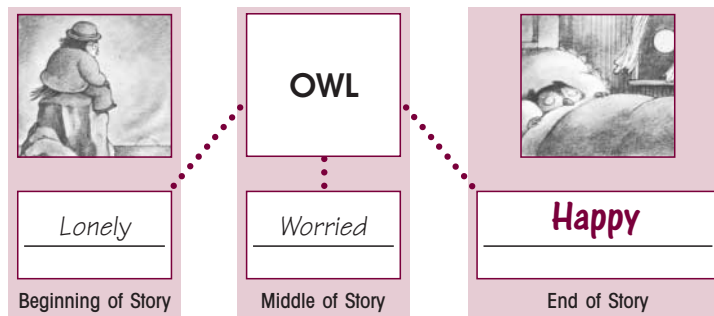

Now write a sentence telling why Owl felt that way at the end of the story.

- Be sure to use the correct capitalization and punctuation for your sentence.

**Owl is happy because his friend the moon is
looking in the window.**

Other acceptable responses:

- Sleepy: Owl is sleepy because he walked home from the seashore.
- Sad: At the end of the story, Owl is sad because he thinks the moon has gone away.

Reading and Language Arts

Item 19 Student Practice Materials page 5.14

Objective 09: Editing Skills

Rubric 3 points

- 1 point for changing *us* to *we*
- 1 point for changing the comma after *read* to a period
- 1 point for capitalizing the *h* in *her*

Note

- Mistakes need not be crossed out as long as they are corrected.
- If the student corrects mistakes in other acceptable ways, give full credit. Ignore any changes made to parts of the sentences that do not have mistakes. Misspellings of corrections are acceptable.

Example of acceptable response:

- 19** Here is part of a letter that a student wrote to Eve Bunting. There are three mistakes. Draw a line through each part that has a mistake, and write the correction above it.

we
Our teacher said ~~us~~ could read any book we wanted. I chose
your book about the grandmother who learned to read, ~~her~~
hard work made her whole family happy.

Reading and Language Arts

Item 25 Student Practice Materials page 5.19

Objective 04: Evaluate and Extend Meaning

Rubric 2 points

- 1 point for using material from the story to illustrate not succeeding [at first]
- 1 point for using material from the story to illustrate trying again

Objective 07: Sentence Structure

Rubric 3 points

- 1 point for writing at least one complete sentence
- 1 point for using correct initial capitalization
- 1 point for using the correct punctuation

Note

- If the student wrote more than one sentence, score only the sentence with the fewest mistakes.

Example of acceptable response:

25 Here is an old saying that gives advice:

If at first you don't succeed, try, try again.

On the lines below, tell how Amelia Earhart followed this advice in the story.

- Write one or two complete sentences. Be sure to use the correct capitalization and punctuation for your sentences.

Amelia's roller coaster didn't work. So she was going to fix it by making the track longer.

Other acceptable responses:

- Amelia crashed when she first tried the roller coaster. She decided it might work if it wasn't so steep, so she was willing to try again.
- The roller coaster was too steep so it crashed. Amelia decided to try again and add more boards.

Mathematics

Item 18 Student Practice Materials page 5.32

Objective 11: Computation and Numerical Estimation

Rubric 2 points

- 1 point for answer of 16 (marbles)
- 1 point for a valid process

Note

- Correct response need not be in the space provided to receive credit. Students receive 1 point for a correct process with an error in computation.

Example of acceptable response:

- 18** Don is carrying 4 marbles in his pocket. His brother is carrying 3 times as many marbles as Don. How many marbles are Don and his brother carrying all together?

Show your work.

$$\begin{aligned}3 \times 4 &= 12 \\ 12 + 4 &= 16\end{aligned}$$

16 marbles

Other acceptable responses:

- $4 + 4 + 4 = 12$
 $12 + 4 = 16$
- Any other acceptable process

Mathematics

Item 19 Student Practice Materials page 5.33

Objective 13: Measurement

Objective 18: Communication

Rubric 3 points

- 1 point for the correct measurement of 6 (centimeters)
- 1 point for 60 (centimeters)
- 1 point for a correct explanation

Example of acceptable response:

19



Use the centimeter side of your ruler to help you solve this problem.

Carmen invented a new unit of measure called a “bink.” This marker is 2 binks long.

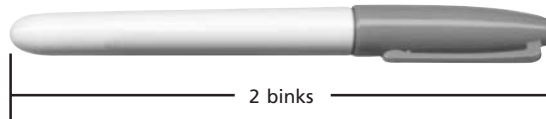

How many **centimeters** long is 1 bink? Write your answer on the line below.

1 bink = 6 centimeters

Carmen is measuring a toy train that is 10 binks long. How many **centimeters** long is the toy train? Write your answer on the line below.

The train is 60 centimeters long.

On the lines below, explain how you found your answer.

The train is 10 binks long. One bink is

6 centimeters. I multiplied 6×10 and

got 60 centimeters.

Other acceptable responses:

- I multiplied 6×10 .
- Any other acceptable method

Mathematics

Item 20 Student Practice Materials page 5.34

Objective 12: Operation Concepts

Objective 17: Problem Solving and Reasoning

Rubric 2 points

- 1 point for each valid response

Example of acceptable response:

20

Sherri bought a pack of gum for 45¢. The pack contained 16 pieces of gum. She gave 2 pieces of gum to each of her friends.



What else is needed to find the number of pieces of gum Sherri had left?

You need to know how many friends Sherri

gave gum to.

What fact written in the box is not needed to find the number of pieces Sherri had left?

You don't need to know how much the gum cost.

Science

Item 13 Student Practice Materials page 5.40

Objective 19: Science Inquiry

Rubric 1 point

- 1 point for indicating that as the temperature decreases (or increases), the number of snails also decreases (or increases) **OR** stating that the snails died, or hid, or left the garden

Example of acceptable response:

- 13** Each day at lunch time, Jackie recorded the air temperature and the number of snails in her garden.

Her record for five days is shown in the table below.



Day of the Week	Number of Snails	Temperature (in °F)
Monday	12	76
Tuesday	10	72
Wednesday	8	63
Thursday	7	61
Friday	5	45

What happens to the number of snails in Jackie's garden as the temperature goes down?

The number of snails gets smaller.

Science

Item 14 Student Practice Materials page 5.40

Objective 20: Physical Science

Rubric 1 point

- 1 point for plotting an X in all the boxes as indicated

Note

- 0 points if a box is omitted or incorrectly marked.

Example of acceptable response:

- 14** Look at the chart. Place an X in the box to show if the object is a solid or a liquid.
The first one has been done for you.

	Solid	Liquid
pencil	X	
sugar	X	
oil		X
wood	X	
water		X

Science

Item 15 Student Practice Materials page 5.41

Objective 19: Science Inquiry

Rubric 2 points

- 1 point for indicating that the pots should be of different sizes **OR** indicating that pots should have different amounts of soil
- 1 point for indicating that the same kind of plant should be put in each pot

Example of acceptable response:

- 15** Your friend wants to find out if using more soil will help a plant grow bigger. For this experiment, your friend is using the three pots and plants shown below.



Describe two things your friend needs to change in order to improve the experiment.

one: **Use different size pots.**

two: **Use the same kind of plant in each pot.**

Social Studies

Item 13 Student Practice Materials page 5.48

Objective 26: Geographic Perspectives

Rubric 2 points

- 1 point for **each** bar correctly drawn

Note

- Give full credit for correctly drawn bars with any sort of markings (i.e., shading, diagonal lines, crosshatching, etc.) or none at all.
- Accepted range is indicated by dotted lines.
- Line graphs are not acceptable for credit.

Example of acceptable response:

- 13** Use the information in the chart above to complete the bar graph below.

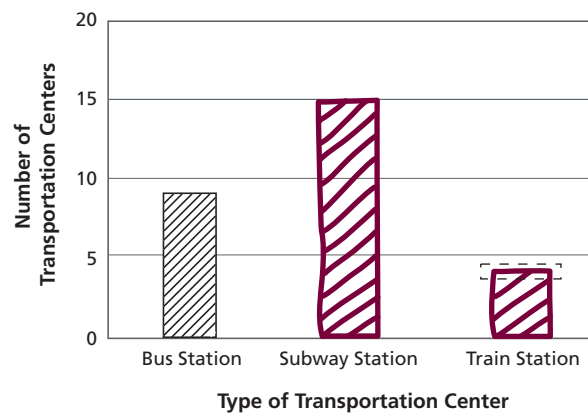

Social Studies

Item 14 Student Practice Materials page 5.50

Objective 28: Civics and Government Perspectives

Rubric 1 point

- Full credit if all numbers are correctly labeled:
4, 2
1, 3

Example of acceptable response:

- 14** These pictures show the steps Carla and her neighbors took to help clean up the river. Put the pictures in the order described in the passage by writing the numbers 1, 2, 3, or 4 in the circle on each picture.



Social Studies

Item 15 Student Practice Materials page 5.51

Objective 27: Historical and Cultural Perspectives

Rubric 2 points

- 1 point for **each** logical grouping with corresponding logical use

Example of acceptable response:

15 Complete the chart below by making groups of two objects that go together. Then tell how they were used. An example has been done for you.

- List two objects for Group 1 and two objects for Group 2.
- Then tell how each **group** of objects was used.

	Objects	How they were used
Example	1. wooden bowl 2. corn grinder	Both were used for preparing food.
Group 1	1. rattle 2. drum	Both were used for _____ ceremonies
Group 2	1. drum 2. bow and arrow	Both were used for _____ war

Other acceptable responses:

- Rattle and drum:
war, warning/alarms, communication, music
- Fish hook and bow and arrow:
Hunting (killing/catching animals), eating/food preparation or acquisition

Introduction to the Teaching Activities

This section of the guide is geared specifically for classroom use. The following pages contain ready-to-use activities that are easily integrated into the classroom curriculum. With their emphasis on interaction and participation, these activities help the teacher introduce the concepts and skills covered in *TerraNova, The Second Edition*.

The activities found in Part 7 are specifically designed to assist the classroom teacher in familiarizing students with the concepts, processes, and skills found in *TerraNova, The Second Edition*. While the items in [Part 4](#) and [Part 5](#) focus on practice in answering questions in a test format, these activities provide students with an opportunity to work in groups, ask questions, and become actively involved in a shared learning experience.

For easy classroom use, each activity is accompanied by the following information:

- the purpose of the activity;
- the objective and thinking skill covered;
- a brief description of the activity;
- complete directions for each step of the activity.

With some activities, a passage, prompt, or worksheet has been included and can be found on separate pages immediately following the activity. These materials are suggested for teacher use and can be substituted or expanded with other appropriate selections. Before beginning an activity, it is recommended that teachers read through the entire activity to learn what preparation might be involved.

The variations found at the end of many activities offer alternate ways to approach the activity. Some of these variations provide basic and more advanced activities for those students who need additional practice or enrichment.

Part 7 can serve as a valuable resource for the classroom teacher. While the class is participating in an activity, the teacher can assess student performance and evaluate how well students are understanding particular concepts. Although the strategies described here do not constitute a complete instructional program, they do provide helpful supplementary activities that can enhance classroom instruction.

Description of the Elements in a Teaching Activity

The following sample shows a Grade 2–3 Reading and Language Arts teaching activity. Each part of the activity is labeled and further described below:

Part 7 Teaching Activities—Reading and Language Arts 7.7

A	ACTIVITY 2	<h3>Baby Elephant Goes to Tea</h3>
B	Purpose	In this activity, students show their understanding of the sequence of events in a story. Objective 02: Basic Understanding Thinking Skill: Organize Information
C	Description	After reading a story, students reorder and illustrate the events in correct sequence.
D	Materials	scissors, tape, large sheets of paper, staplers
E	Directions	 <ol style="list-style-type: none"> 1. Getting Started Distribute copies of Worksheet 1. Have the students read the story “Baby Elephant Goes to Tea.” 2. Discuss Ask students questions about the sequence of events in the story. In your questions, use words such as <i>first</i>, <i>next</i>, <i>then</i>, <i>before</i>, <i>after</i>, and <i>last</i>. Questions could include the following: <ul style="list-style-type: none"> ♦ What happened first in the story? (Baby Elephant went to Rabbit’s house.) ♦ What happened after Baby Elephant put her head in Rabbit’s house? (She got stuck.) ♦ What happened before Baby Elephant landed on the ground? (Rabbit pulled her tail hard.) ♦ What happened last in the story? (Rabbit suggested having a picnic outside.) 3. Worksheet Distribute copies of Worksheet 2. Explain that these sentences tell what happened in the story, but they are out of order. Divide the class into six groups. Assign one sentence to each group and have them cut out and tape it onto a larger sheet of paper, and then draw a picture that describes that part of the story. Have students lay the illustrated pages on the floor in the correct order. 4. Make a Book Have students read the sentences aloud to be sure they are sequenced correctly and make sense. Have students make a cover page and then staple the pages together to make a book. 5. Conclude Activity To conclude the activity, ask students to tell what might happen next in the story. Ask the following question: <ul style="list-style-type: none"> ♦ What do you think Rabbit and Baby Elephant will do after the picnic?
F	Variation	<p>Basic Help students number the sentences on the worksheet. Have them use the numbered sentences to retell the events of the story in the correct order.</p> <p>Advanced Have students write a story about what might happen the day Baby Elephant invites Rabbit to her house for tea.</p>

- A** Activity number and title.
- B** The purpose of the activity.
- C** The objective and thinking skill covered by the activity.
- D** A brief description of the activity.
- E** A list of materials needed. Materials that are common to classrooms (paper, pencils, etc.) or that are provided in this binder (passages, worksheets), are not listed.
- F** Complete directions for each step of the activity.
- G** Answers (in parentheses) are provided in some cases as a convenience to teachers.
- H** Alternate ways to approach the activity. Some activities provide basic and more advanced activities for those students who need additional practice or enrichment.

Reading and Language Arts

Teaching Activities

Activity Number and Title		<i>TerraNova, The Second Edition</i> Objective Number and Title	Activity Worksheet	Activity Page Number
1	A Scary Bug	02 Basic Understanding	X	7.5
2	Baby Elephant Goes to Tea	02 Basic Understanding	X	7.7
3	Where, Oh Where, Is Elise?	03 Analyze Text		7.10
4	You Can Do It!	03 Analyze Text	X	7.11
5	The Missing Name	04 Evaluate and Extend Meaning	X	7.14
6	Kitten Care	04 Evaluate and Extend Meaning	X	7.16
7	What's That Word?	05 Identify Reading Strategies	X	7.18
8	The Treasure Hunt	05 Identify Reading Strategies	X	7.20
9	Making Words	06 Introduction to Print	X	7.23
10	Make Sentences Complete	07 Sentence Structure	X	7.25
11	Put Them Together	07 Sentence Structure	X	7.27
12	Growing Vegetables	08 Writing Strategies	X	7.29
13	Mix It!	08 Writing Strategies	X	7.31
14	Where Are the Capital Letters?	09 Editing Skills	X	7.33
15	Scavenger Hunt	09 Editing Skills		7.35
Answers to Student Worksheets				7.93

ACTIVITY

1

A Scary Bug

Purpose

In this activity, students show their understanding of a story.

Objective 02: Basic Understanding **Thinking Skill:** Gather Information

Description

After reading a story or hearing it read aloud, students identify information stated in the story.

**Directions**

- 1. Getting Started** Show an illustration of a cricket or draw one on the board before you read the selection. Ask the students the following questions:
 - ◆ Have you ever found a bug that wasn't a spider?
 - ◆ How many legs did it have?
- 2. Worksheet** Distribute copies of the worksheet. Read aloud, or have the students read, the story "A Scary Bug."
- 3. Discuss** Ask questions that require students to state information from the story, such as the following:
 - ◆ Where do Ana and Marie find the bug? (under the bed)
 - ◆ What color is the bug Ana and Marie find? (brown)
 - ◆ How big is the cricket? (an inch long)
 - ◆ How do you think a cricket compares to the size of an ant, a butterfly, and a bumblebee?
 - ◆ How many legs does a cricket have? (six)
 - ◆ How many legs does a spider have? (eight)
 - ◆ Who in the story knows that the bug is not dangerous? (Marie)
 - ◆ What does Marie do with the cricket? (tosses it out the window)
- 4. Conclude Activity** To conclude the activity, ask students the following questions:
 - ◆ Why do you think Ana was scared?
 - ◆ What would you have done if you had seen the bug?

Variation

Have students underline the phrases in the story that give information with which to answer each question.

Name _____

A Scary Bug-Worksheet

Directions: Read the story. Then think about what happens in the story.

A Scary Bug

“Chir—rup!” A sound came from under the bed.

“Yikes!” Ana said. “What was that?”

Ana and Marie looked under the bed.

They saw a brown bug about one inch long.

“It’s a spider!” Ana yelled. “Let’s get out of here!”

“Don’t be scared,” said Marie. “It isn’t a spider. A spider has eight legs. This bug only has six.” Marie scooped it up.

“Don’t do that!” Ana warned. “It will bite you.”

Marie smiled and tossed the bug out the window.

“Didn’t it bite you?” asked Ana.

“No, it’s a cricket,” said Marie. “Crickets never bite and some people think they are good luck.”



ACTIVITY

2

Baby Elephant Goes to Tea

Purpose

In this activity, students show their understanding of the sequence of events in a story.

Objective 02: Basic Understanding **Thinking Skill:** Organize Information

Description

After reading a story, students reorder and illustrate the events in correct sequence.

Materials

scissors, tape, large sheets of paper, staplers

**Directions**

- 1. Getting Started** Distribute copies of Worksheet 1. Have the students read the story “Baby Elephant Goes to Tea.”
- 2. Discuss** Ask students questions about the sequence of events in the story. In your questions, use words such as *first*, *next*, *then*, *before*, *after*, and *last*. Questions could include the following:
 - ♦ What happened first in the story? (Baby Elephant went to Rabbit’s house.)
 - ♦ What happened after Baby Elephant put her head in Rabbit’s house? (She got stuck.)
 - ♦ What happened before Baby Elephant landed on the ground? (Rabbit pulled her tail hard.)
 - ♦ What happened last in the story? (Rabbit suggested having a picnic outside.)
- 3. Worksheet** Distribute copies of Worksheet 2. Explain that these sentences tell what happened in the story, but they are out of order. Divide the class into six groups. Assign one sentence to each group and have them cut it out and tape it onto a larger sheet of paper, and then draw a picture that describes that part of the story. Have students lay the illustrated pages on the floor in the correct order.
- 4. Make a Book** Have students read the sentences aloud to be sure they are sequenced correctly and make sense. Have students make a cover page and then staple the pages together to make a book.
- 5. Conclude Activity** To conclude the activity, ask students to tell what might happen next in the story. Ask the following question:
 - ♦ What do you think Rabbit and Baby Elephant will do after the picnic?

Variation

Basic Help students number the sentences on the worksheet. Have them use the numbered sentences to retell the events of the story in the correct order.

Advanced Have students write a story about what might happen the day Baby Elephant invites Rabbit to her house for tea.

Name _____

Baby Elephant Goes to Tea-Worksheet 1

Directions: Read the story. Then think about what happens in the story.

Baby Elephant Goes to Tea

Baby Elephant went to Rabbit's house for tea.

"Come in!" said Rabbit.

Baby Elephant looked at the small house. She put her foot inside and felt the warmth of the fire.

"Don't be shy! Put your head in," Rabbit said.

Baby Elephant put her head in. She could smell the cake, but Baby Elephant was stuck. She couldn't get in or out.

Rabbit jumped over Baby Elephant and pulled her tail as hard as she could.

PLOP, FLOP! Baby Elephant landed on the ground outside.

"I'm too big to come in for tea," Baby Elephant said.

"No, you're not," said Rabbit. "My door is too small! We'll have a picnic outside instead."

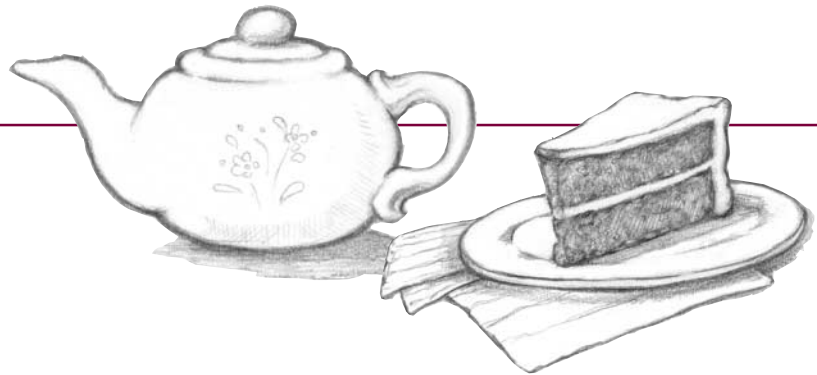

Name _____

Baby Elephant Goes to Tea-Worksheet 2

Directions: These sentences tell what happened in the story. Cut the strips apart. Then put them in the correct order.

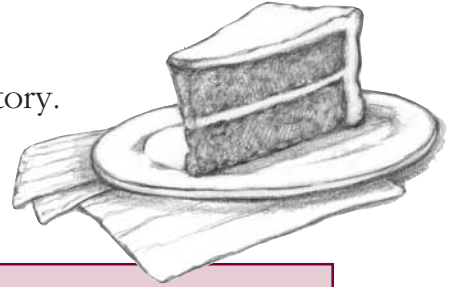

First, Baby Elephant walked to Rabbit's house.

So then, Rabbit pulled Baby Elephant's tail and pulled her out of the house.

Finally, Baby Elephant and Rabbit had tea and cake outside.

Next, Baby Elephant put her head in and got stuck.

Then Baby Elephant put her foot in Rabbit's house.

Baby Elephant landed on the ground outside.

ACTIVITY

3

Where, Oh Where, Is Elise?

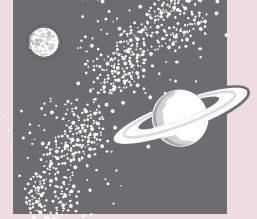
**Purpose**

This activity gives students practice in drawing conclusions about a story.

Objective 03: Analyze Text **Thinking Skill:** Analyze Information

Description

Using prior knowledge and clues from the text, students draw conclusions after reading a story.

Directions

- 1. Getting Started** Play a game of “Where Am I?” Provide students with a riddle for a particular setting, and have students use your clues to guess where you are.

For example: It is very hot. I need a drink of water. I see sand all around me. Where am I? (desert)

- 2. Read Aloud** Tell students you are going to read a story. Ask them to listen carefully and then decide where the main character is.

Elise opens her eyes. She loosens the straps that hold her sleeping bag to the ceiling. Then she floats gently to the doorway. She says “Good morning” to Jim, a crew member. Jim enters the sleeping area. It is his turn to catch a few winks. When he wakes up, it will be Greg’s turn.

Elise greets three astronauts in the kitchen. They are eating breakfast. The oatmeal and dried cherries look delicious!

Soon, Elise will take a walk to make repairs outside. She will wear a special suit. Without the suit, Elise will not be able to breathe. The suit will also protect her from the cold.

- 3. Discuss** Ask students to draw conclusions about the story. Ask questions such as the following:

- ◆ Where does this story take place? How do you know? (on a spaceship)
- ◆ Were all of the astronauts sleeping at the same time in the story? How do you know? (no; the astronaut Jim is going to sleep as the others eat breakfast)
- ◆ How many astronauts are on the trip? How do you know? (at least five, counting Elise)

- 4. Conclude Activity** To conclude the activity, ask students the following questions:

- ◆ Imagine that Elise is working as an underwater photographer. What parts of the story would be different?
- ◆ Where would Elise be?
- ◆ What would she be wearing?

Variation

Read aloud a book with a more complicated sequence of events (e.g., a nonfiction book about astronauts living in space). Have students tell whether they think they would like to live in space one day, and have them explain why or why not.

ACTIVITY

4

You Can Do It!

Purpose

This activity helps students identify and describe characters in a story.

Objective 03: Analyze Text

Thinking Skills: Analyze Information; Synthesize Elements

Description

Students listen to or read a story and identify characters and their actions. They decide what the action tells us about the characters. They also read about different characters and choose words that best describe them.

**Directions**

- 1. Getting Started** Ask students to think about what a character's actions in a story can tell about that character. (For example, even though Cinderella's stepsisters treated her cruelly, Cinderella was kind and gentle to animals, even mice, and to her stepsisters. Although Peter Pan was just a boy, he was brave and fought pirates.) Ask students to think about characters in their favorite stories and describe them.
- 2. Worksheet** Distribute copies of Worksheet 1. Read aloud, or have the students read, the story "You Can Do It!"
- 3. Complete the Chart** Divide students into small groups. Have them work together to fill in the chart on the worksheet. Or discuss the story and its characters as an entire class activity, and fill in the chart as a class.
- 4. Discuss** Ask the groups to compare their answers.
- 5. Conclude Activity** Distribute copies of Worksheet 2. Have students read each description about a person and then complete each sentence with the correct descriptive word from the box.

Variation

Basic Have pairs of students role-play other school scenarios in which they might feel as Ava does at her recital.

Advanced Have students write descriptions of their favorite story characters and read them to the class. Let their classmates guess the identity of each character.

Name _____

You Can Do It!—Worksheet 1

Directions: Read the story. Then fill in the chart below.

You Can Do It!

People were clapping. That meant one thing to Ava. It was her turn to play the piano. Ava's heart beat loudly. Her mouth was dry. She swallowed hard and walked out onto the stage.

Her parents watched her. Everyone was quiet. Ava sat down and started to play. Suddenly, she felt frightened. Would she forget the music? Would she forget to play the right notes?

Then she remembered what her mother had told her.

“You practiced hard. I'm proud of you, even if you miss every note.”

Ava's hands touched the piano keys again. Her fingers began playing. She knew the music perfectly. She played her very best!

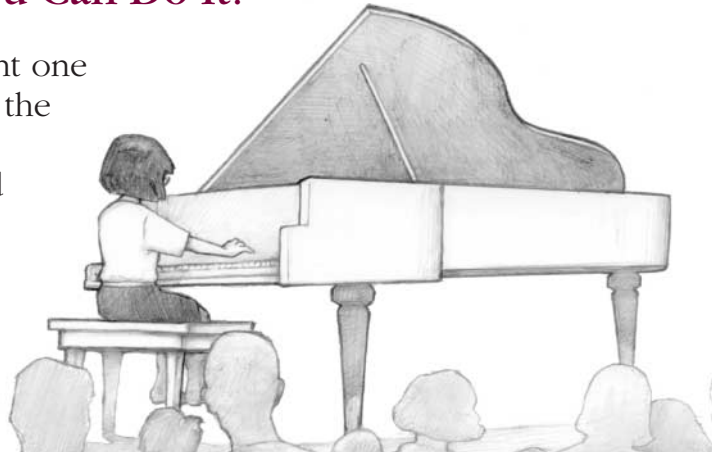

Name of Character	What the Character Does	What This Shows About the Character
Ava		
Ava's mom		

Name _____

You Can Do It!—Worksheet 2

Directions: Read the words in the box. They describe or tell about a person. Complete each sentence below by writing in the correct word from the box.

brave**funny****careful****shy****hard-working**

- 1** David is nine years old. His sister gave him a rusty old bike. David worked and worked on the bike. He cleaned it and polished it. He put air in the tires. He painted the bike, too.



David is _____.



- 2** The clown pulled a hat over her face. Then she stood on her head and waved with her feet.

The clown is _____.

- 3** Alma never rode her bike without the training wheels. Her dad said she was ready to try. He had his hand on the back of the bike. Alma felt a little afraid. Then she said, "Okay, let's go!"



Alma was _____.



- 4** Jeff was happy that his mother let him use the computer. After he used it, he remembered to turn it off. He always remembered to put the plastic cover over it.

Jeff was _____.

- 5** Tim asked Sean to sit beside him at lunch. Sean didn't know Tim very well. He wasn't sure what to say to Tim.



Sean was _____.

ACTIVITY

5

The Missing Name

Purpose

This activity gives students practice predicting what will happen next in a story.

Objective 04: Evaluate and Extend Meaning

Thinking Skills: Analyze Information; Evaluate Outcomes

Description

Using textual clues and what they already know, students make and discuss predictions about a story they hear or read.

Materials

picture book that has a plot or story line

**Directions**

- Getting Started** Read aloud the picture book. Before turning each page, have students predict what they think will happen next. Have them explain why they made each prediction.
- Worksheet** Make copies of the worksheet. Then fold each worksheet at the dotted line so that “The Missing Name” is visible. Distribute the worksheets. Read aloud, or have the students read, the first part of the story “The Missing Name.”
- Discuss** Encourage students to make predictions about what will happen next in the story. Ask the following question:
 - ♦ What do you think will happen to Marc’s artwork? (It might get lost; the wrong person will get credit for it; etc.)
- Conclude Activity** Read the rest of the story aloud or have students read it. Have students compare their predictions with what actually happened in the story. To conclude the activity, ask students the following questions:
 - ♦ What do you think Marc will see when he visits City Hall with his class?
 - ♦ Do you think Marc will remember to sign his name on his artwork from now on? Why or why not?

Variation

Divide students into pairs to write a short story together. Provide each pair with a long sheet of paper, and fold up the bottom half of the paper to the middle of the page. Have one student write the beginning of a story on the top portion of the paper. Then have the other student read the story, unfold the paper, and write the second part of the story on the bottom portion of the paper, below the middle of the paper. The second part of the story should give the conclusion of the story, or tell how it all turns out.

Have the second student fold the paper up again and invite the first student to predict the conclusion before unfolding the paper and reading the second part of the story.

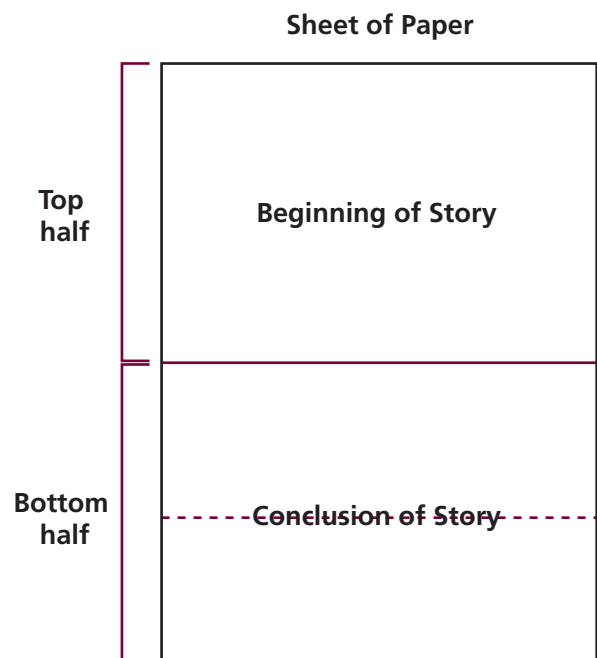

Name _____

The Missing Name-Worksheet

Directions: Read the story.

The Missing Name

Marc's teacher asked her students to put their names on the back of their artwork. That way, she could tell who had drawn each picture and to whom to return it at the end of the lesson.

Marc loved to paint, draw, and work with clay. Art was his favorite class. However, Marc was always in such a hurry to start a new project that he forgot to sign his work.

One day a famous artist came to Marc's school. He helped the children make pictures using watercolor paints. When the class was over, the artist collected all the pieces and took them to City Hall to be put on display.

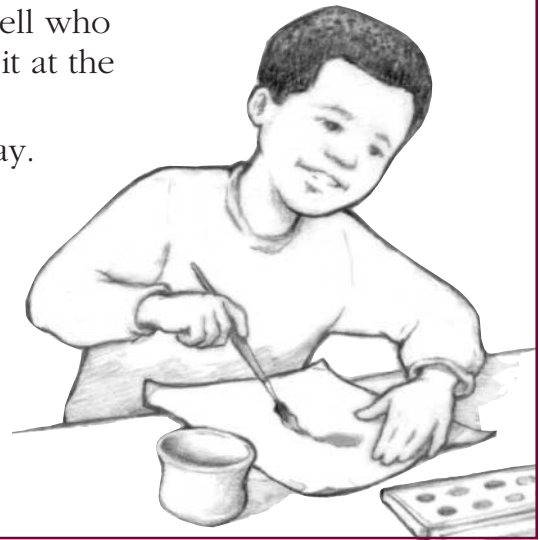

What do you think will happen to Marc's artwork?

(Fold)

Directions: Now read the rest of the story.

When he got to City Hall, the artist hung all of the students' paintings on the wall. Next to each painting he made a card with the student's name on it. When he got to Marc's painting, he saw that there was no name on the back.

The artist called Marc's teacher and told her about the problem. She said that the mystery painting must be Marc's. "He always forgets to sign his name," she said.

ACTIVITY

6

Kitten Care

Purpose

This activity gives students practice applying or using what they learn from a passage.

Objective 04: Evaluate and Extend Meaning

Thinking Skills: Analyze Information; Generate Ideas

Description

Students read a passage about pet care and complete a chart.

**Directions**

- 1. Getting Started** Talk to students about reading material for information.
- 2. Worksheet** Distribute copies of the worksheet. Read aloud, or have the students read, “Caring for Your New Kitten.”
- 3. Complete the Checklist** Tell the students to pretend that they have a new pet. The new pet can be a puppy, a fish, a bird, a hamster, or a snake. Have the students fill in the checklist to show how they would take care of their new pet.
- 4. Conclude Activity** On the board, make a checklist of things from the story and from your own knowledge that a kitten needs. Then ask the students if the same things also apply to their pets.

Variation

Basic Have students share with their classmates their experiences with animals. Have the students rewrite the story, substituting “puppy” for “kitten.” Ask if there are any problems with the story if “puppy” is used.

Advanced Ask students to write a story from a pet’s point of view.

Name _____

Kitten Care-Worksheet

Directions: Read the story. Then fill in the chart.

Caring for Your New Kitten

Kittens are playful pets. But when you bring your kitten home, it needs special care.

A kitten needs a warm place to sleep. Make the bed soft and place it in a quiet place. Then the kitten will feel safe.

Kittens love to play. They like balls, yarn, and small toys. Play gently so you don't scare the kitten.

Make sure your kitten has fresh water each day. Make sure it gets food in the morning and evening.

Your kitten may think you are its mom. It will cuddle with you. Pet it gently. You will have a loyal friend!



Directions: Pretend you have a new pet—a puppy, a fish, a bird, a hamster, or a snake. Using what you read about in the story, put a mark in the boxes that show what your new pet will need.

	Puppy	Fish	Bird	Hamster	Snake
Bed					
Quiet					
Toys					
Water					
Food					
Love					
Other					

ACTIVITY

7

What's That Word?

Purpose

This activity gives students practice using context clues to identify unfamiliar vocabulary.

Objective 05: Identify Reading Strategies **Thinking Skill:** Analyze Information

Description

Students use context clues to identify unfamiliar words in short passages.

**Directions**

- 1. Getting Started** Explain that sometimes you can find out the meaning of a word by reading the whole sentence or story first, and then use the words you know as clues to figure out the unknown word.
- 2. Worksheet** Distribute copies of the worksheet. Read aloud the first story.
- 3. Discuss** Ask students what they think *carnival* means. Reread the story. Have students raise their hands when they hear words that help them know what *carnival* means.
- 4. Continue** Repeat the procedure with stories 2, 3, and 4.
- 5. Conclude Activity** To conclude the activity, ask students the following questions:
 - ♦ What would you do first when you read an unfamiliar word?
 - ♦ Do you look for clues in the story or article, or look up the word in the dictionary?

Variation

Basic Write each passage on the board and guide students in identifying the words and phrases that give clues to the word's meaning. Then have students work in pairs to write the definition or draw a picture to show the meaning of each word.

Advanced Have students find and define unfamiliar words in books or magazine articles they are reading. Have them explain how they figured out the meaning of each word.

Name _____

What's That Word?—Worksheet

1

Carla's school holds a **carnival** to raise money for the coming year. Students sell tickets. Teachers and parents work in the game and food booths. Carla likes to play all the games and go on the rides. Everyone has lots of fun.

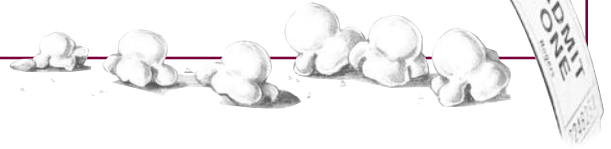

Carnival means _____.

2



Carla loves to read, and she has **numerous** books. They fill up two bookshelves in her room.

Numerous means _____.

3

Carla turned on the **faucet** and picked up the garden hose. It was a hot day and she didn't want the plants to get too dry.



Faucet means _____.

4

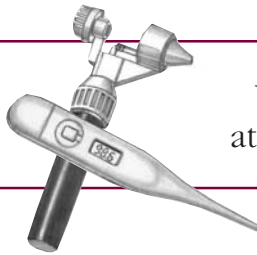

When Carla was ill, she went to a **physician**. He looked at her sore throat.

Physician means _____.

ACTIVITY

8

The Treasure Hunt

Purpose

In this activity, students show their understanding of how to use graphic strategies, such as referring to a map while reading.

Objective 05: Identify Reading Strategies **Thinking Skill:** Analyze Information

Description

Students listen to a story and use a map to find the location of a hidden treasure.

Directions

- 1. Getting Started** Have students work in pairs.
- 2. Worksheet** Distribute copies of the worksheet. Point out the compass rose. Explain that it indicates the directions north, south, east, and west. Tell students you will read them a story. Have the students follow along as you read the directions at the top of the worksheet.
- 3. Read Aloud** Read aloud the following:

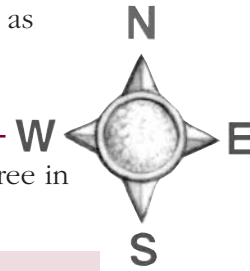

Jenny and Corey stared at the note. They had found it on a tree in Grandpa's backyard. This is what it said:

Hello, Jenny and Corey.

Good job! You found my note. I have drawn a map for you. You will find the first clue to my treasure hunt in the place where there are breakfast treats. Good luck!

Love,
Grandpa

The two children looked at the map. Then they noticed a tree house at the top of the tree. Sometimes they liked to eat breakfast up there. The treasure hunt began!

Jenny and Corey climbed up to the _____. (1—tree house)
But there were no breakfast treats there.

- 4. Read the Map** Check to see that students have written a number 1 and the words *tree house* on their maps where the treasure hunt begins.
- 5. Conclude Activity** Read the rest of the story. Pause before each blank. Have students write the names of the places visited on their maps and the numbers showing the order of their stops. Have students share their answers at the end of the activity.

“Let’s check in the kitchen,” said Corey. So the two ran east to _____. (2—Grandpa’s house) But no breakfast treats were there, either. *[Check to see that students have drawn an arrow pointing east from the tree house and have written a number 2 by Grandpa’s house.]*

The Treasure Hunt—continued

“I’ve got it,” said Jenny. “We all love oranges for breakfast.”

Quickly, they raced north to the _____. (3—orange grove) *[Check to see that students have drawn an arrow pointing north from Grandpa’s house and have written a number 3 by the orange grove.]*

Taped to the very first tree in the grove was a note that said, “You’ll find your treasure on a sandy shore!” Jenny and Corey ran west, then south. *[Check to see that students have drawn arrows pointing west and then south.]*

When they got to the _____, (4—sandy beach) Grandpa was waiting with a great big smile—and a picnic for Jenny and Corey aboard his brand new rowboat! *[Check to see that students have written a number 4 by the sandy beach.]*

Variation _____

Basic Retrace the steps of the treasure hunt. Have students point to each numbered stop along the way from 1 to 4.

Advanced Have students make a map of the classroom and plan a class treasure hunt.





Name _____

The Treasure Hunt-Worksheet

Directions: Follow the path of the treasure hunt. As you listen to the story, you will hear about the places Jenny and Corey look for their treasure. Write a number 1 and the place name on the starting point. Continue numbering and writing the place names of each stop. Then draw arrows connecting all the places that Jenny and Corey visit.

Grandpa's Island

KEY

SANDY BEACH 	ORANGE GROVE 
TREE HOUSE 	GRANDPA'S HOUSE 

ACTIVITY

9

Making Words

Purpose

In this activity, students demonstrate knowledge of letter sounds in words.

Objective 06: Introduction to Print **Thinking Skill:** Organize Information

Description

Students sort sounds and make new words by substituting sounds.

Materials

overhead projector (optional)

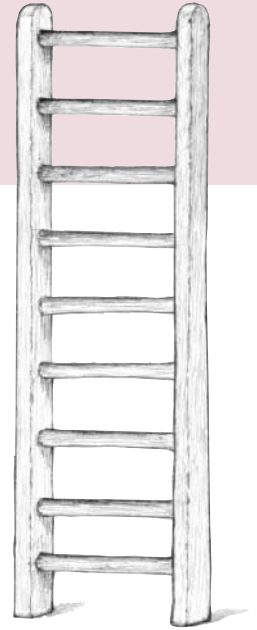
**Directions**

- 1. Getting Started** Write the following words on the board or use an overhead projector:
clip, shell, drum, walk, bread, drop, coin
- 2. Discuss** Ask students the following questions:
 - ◆ Which word begins like *shovel*? (shell)
 - ◆ Which word begins like *class*? (clip)
 - ◆ Which word ends like *stem*? (drum)
 - ◆ Which word rhymes with *talk*? (walk)
 - ◆ Which word has the same vowel sound you hear in *boy*? (coin)
 - ◆ Which word begins like *dress* and ends like *cap*? (drop)
 - ◆ Which word begins like *breakfast* and ends like *red*? (bread)
- 3. Climb the Ladder** Draw a ladder on the board or use an overhead projector. (See the worksheet.) Begin a word ladder by writing the word *hip* on the bottom step. Guide students to substitute or add letters to change the word—one vowel sound or consonant sound at a time. Write each new word on the step above the last word (*hip, sip, sit, sir, stir, star, start; date, late, lake, take, shake, shame, name*).
- 4. Worksheet** Distribute copies of the worksheet. Have students follow the directions to make new words by changing one or two letters (one sound) of the word and writing the new word on the next rung up. In this way, they “climb” to the top.
- 5. Conclude Activity** Have students make their own word ladders to share with the class.

Variation

Basic If they need more help with sound/symbol relationships, have students make chains of word families, such as *ought, brought, sought, fought, thought*, etc.

Advanced Have students write riddles for classmates to solve, such as the following:

- ◆ What word rhymes with *goat* and begins like *box*?
- ◆ What word rhymes with *speak* and begins like *bat*?

Name _____

Making Words-Worksheet

Word Ladders

Directions: Follow the steps to make new words. Write each new word above the last one on the word ladder.

Steps (start at the bottom):

Try one of your own:

8 Change the **n** to **t**.

7 Change the **l** to **cr**.

6 Change the **i** to **a**.

5 Change the **m** to **l**.

4 Change the **c** to **n**.

3 Change the **r** to **m**.

2 Change the **a** to **i**.

1 Change the **f** to **r**.

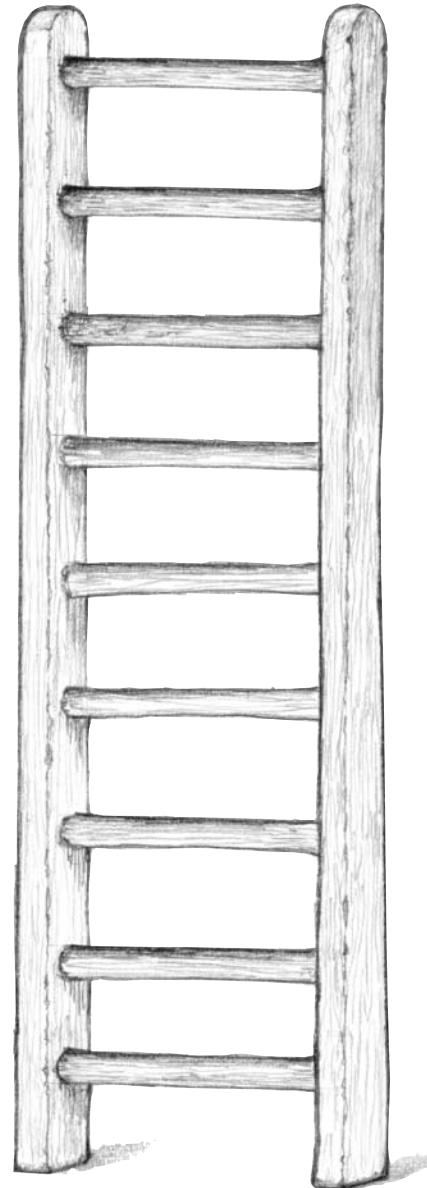
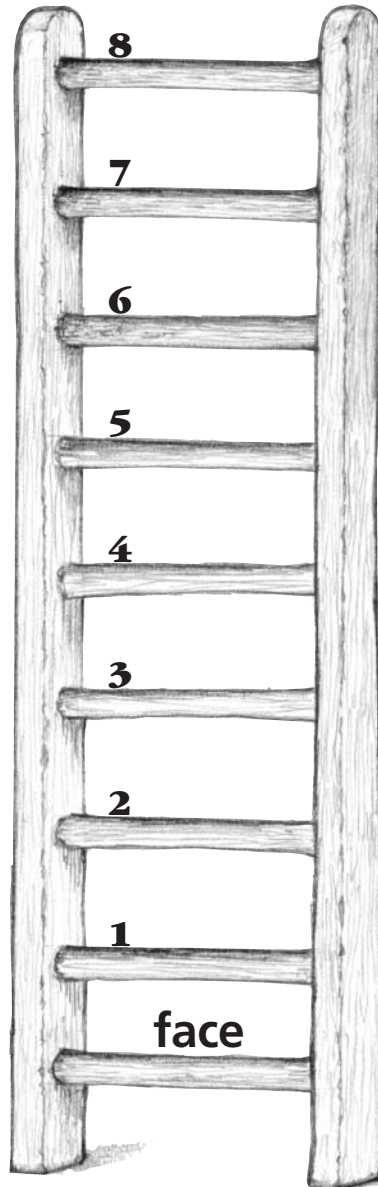

ACTIVITY

10

Make Sentences Complete

Purpose

This activity gives students practice distinguishing between complete sentences, fragments, and run-ons.

Objective 07: Sentence Structure **Thinking Skill:** Analyze Information

Description

Students identify complete sentences and create complete sentences out of fragments and run-ons.

Materials

overhead projector (optional)

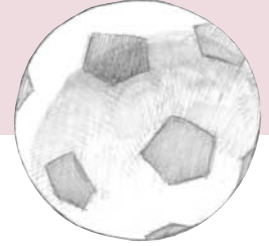
**Directions**

- 1. Getting Started** Explain that a complete sentence expresses a complete thought. It has a subject that tells who or what the sentence is about. It has a verb that shows action or tells about the subject. A sentence that does not express a complete thought is a *fragment*. A sentence that expresses more than one complete thought is a *run-on* sentence and should be separated into two sentences.
- 2. Discuss** Write the following sentences on the board or use an overhead projector:
How to play soccer.
Our coach taught us how to play soccer.
We learned how to kick we learned how to block.

Read the sentences aloud. Ask students which sentence is complete. Have them identify the fragment and the run-on sentence. Then discuss how to make the fragment a complete sentence, and how to turn the run-on sentence into two complete sentences. Explain that there are two ways to correct a run-on sentence: 1) you can break it into two sentences; or, 2) you can connect the two thoughts with a linking word, such as *and*, *but*, or *or*.
- 3. Worksheet** Distribute copies of the worksheet. Have students read the passage, circle each fragment, and underline each run-on sentence. Then have them rewrite the passage using all complete sentences.
- 4. Conclude Activity** Have students exchange worksheets with a partner and check each other's work.

Variation

Basic Write the complete sentences from the story on the board. Have students circle each subject and underline each verb.

Advanced Have students work in pairs. Both students write three or four sentences about their favorite topic. Partners should then edit each other's work, checking for sentence fragments and run-ons.

Name _____

Make Sentences Complete-Worksheet

Directions: Read the story. Circle each fragment. Underline each run-on sentence. Then rewrite the story correctly on the lines below.

My Soccer Team

My soccer team. We played against the Bears on Saturday. Many fans came they cheered for both teams.

Scored at the beginning of the game. We tried to stop them from scoring again. Our goalie did a good job he blocked a great shot.

After we scored a goal. We were tied. Scored another point in the last five minutes. We won the final score was 2 to 1! An exciting game!

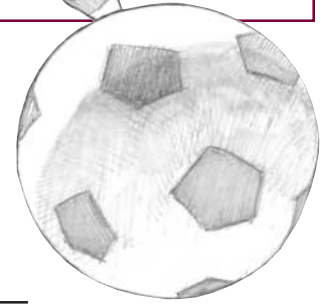
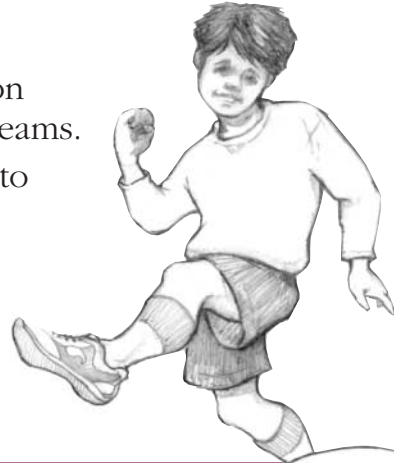

ACTIVITY

11

Put Them Together

Purpose

In this activity, students practice combining sentences.

Objective 07: Sentence Structure **Thinking Skill:** Synthesize Elements

Description

Students read two sentences and combine them with the linking words *and*, *but*, or *or*.

Materials

overhead projector (optional)

**Directions**

- 1. Getting Started** Explain that sometimes you can combine two sentences just by linking the subjects. Write the following sentences on the board or use an overhead projector:

Jake has red curly hair.

Helen has red curly hair.

Jake and Helen have red curly hair.

Note that the verb becomes a plural verb.

- 2. Discuss** Explain that you can also combine two sentences by linking what the subject does. Write the following sentences on the board or use an overhead projector:

Jamie flies a plane.

Jamie sails a boat.

Jamie flies a plane and sails a boat.

Write the following sentences on the board or use an overhead projector. As you say these sentence pairs, ask students to combine them. Point out that there may be more than one way to do so.

Chan plays soccer. Chan takes piano lessons.

We can have chicken. We can have pizza.

Apples are fruits. Pears are fruits.

Our teacher is smart. Our teacher is kind.

Evan got a letter in the mail. Evan got a magazine in the mail.

We tried to catch the bus. The bus pulled away.

- 3. Worksheet** Distribute copies of the worksheet. Have students complete it individually or as a class.
- 4. Conclude Activity** Have students exchange worksheets with a partner and check each other's work or write the combined sentences on the board.

Variation

Basic Have students work with the examples above to distinguish the three ways of combining sentences: linking the sentences themselves; linking sentence subjects; linking sentence predicates.

Advanced Ask students to write three or four pairs of sentences similar to those on the board. Then have students give the sentences to a partner to combine.

Name _____

Put Them Together-Worksheet

Directions: Read each set of sentences. Combine the sentences to make only one. Use *and*, *but*, or *or* to put the sentences together.

- 1** My grandmother wanted to go to the aquarium. I wanted to go to the aquarium.

- 2** We waited in line. We bought tickets.

- 3** We saw a swordfish. We saw a jellyfish.

- 4** We didn't feed the otters. We didn't see the turtles.

- 5** The eels were strange looking. The sharks were scary.

- 6** A diver went inside a big tank. A diver fed all the fish.

- 7** Grandma bought postcards. I bought a dolphin T-shirt.

- 8** My grandmother took lots of pictures. I did not take lots of pictures.

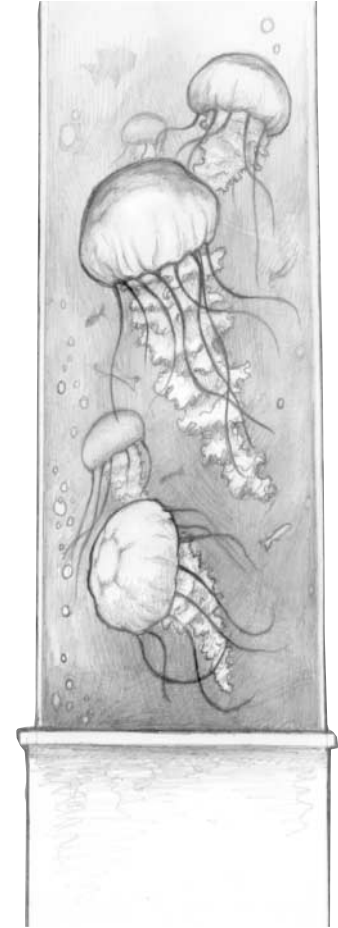

ACTIVITY

12

Growing Vegetables

Purpose

This activity gives students practice choosing relevant sentences in a paragraph.

Objective 08: Writing Strategies **Thinking Skills:** Analyze Information; Synthesize Elements

Description

Students read a story about a family’s garden and use the information to correct a how-to paragraph.

**Directions**

- 1. Getting Started** Remind students that when we write, we need to include what is important to the topic. Including too much information can be confusing.
- 2. Worksheet** Distribute copies of the worksheet. Read aloud, or have the students read, the story “Growing Vegetables.”
- 3. Discuss** Discuss the steps for growing vegetables that are described in the story. Ask students what they noticed about some of the sentences in the story. Point out that some sentences don’t belong in the story because they have nothing to do with growing vegetables.
- 4. Make Corrections** Tell students that they are to correct the paragraph that explains how to plant vegetables. Ask students the following questions:
 - ♦ Which information in the story is important to include?
 - ♦ Which information is not important, and should be left out?
 Have students cross out sentences that do not belong.
- 5. Conclude Activity** To conclude the activity, ask students the following question:
 - ♦ Why is it important, when telling someone how to do something, to include only information that is necessary?

Variation

Hand out copies of the story and read it aloud. As you read a sentence that gives information about growing vegetables, have the students underline the sentence. Then have students use the underlined sentences to write a paragraph.

Name _____

Growing Vegetables-Worksheet

Directions: Read the story. Cross out sentences that do not belong in the story.

Growing Vegetables

My Dad said we could try to grow vegetables in our backyard. We all helped to turn over the soil and rake the dirt. Sand is made from pieces of rock. Then we raked the dirt into rows.

Dad said we could each choose the vegetable we wanted to grow and the row we wanted to plant in. My sister likes to put ketchup on her vegetables. I put green bean seeds in my row. Then I watered and waited.

My dad works near a big park. After a few weeks, I saw something green peeking through the dirt! It was a little green bean plant!

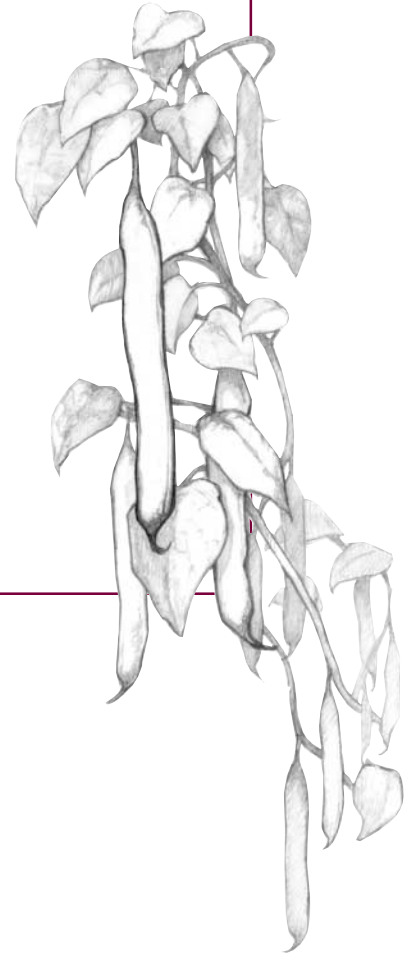

ACTIVITY

13

Mix It!

Purpose

This activity gives students practice in writing directions in sequential order.

Objective 08: Writing Strategies **Thinking Skills:** Organize Information; Synthesize Elements

Description

Students determine the correct sequence of steps in a recipe. Then they write directions to match pictures showing each step in the recipe.

Materials

scissors, stapler, overhead projector (optional)

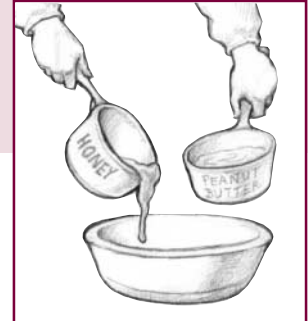
**Directions**

- 1. Getting Started** Write this recipe on the board or use an overhead projector. Read aloud the recipe, or have students take turns reading parts aloud.

Yummy Peanut Butter Treats

You Will Need:

- 4 tablespoons smooth peanut butter
- 1/2 cup honey
- 1/2 cup granola
- 1/4 cup raisins
- 1/2 cup shredded coconut

What to Do:

1. Blend the peanut butter and honey in a bowl with a large spoon. Add the granola and raisins and mix well. Cover the bowl with plastic wrap. Refrigerate for thirty minutes.
2. When the batter is chilled, scoop out a teaspoon of the mixture. Roll it into a ball with your hands on a clean surface. Then roll the ball in the coconut and place on a plate. The mixture should make about 24 treats.
3. Chill the treats for at least another hour before eating.

- 2. Worksheet** Distribute copies of the worksheet. Explain that recipes can also be written as a list of numbered steps. Tell students that the pictures on the worksheet show the steps in making Yummy Peanut Butter Treats, but they are out of order. Have students cut out the pictures and then put them in the correct order. Tell students to number each picture from 1 to 6. Under each picture, have students write a sentence or two that describes the step in the recipe. Tell students to use their own words.
- 3. Make a Book** Have students staple the recipe pages together in the correct order to make a small booklet. Have students make covers for their recipe booklets, and then exchange their booklets with a partner. Tell students to read each other's recipes.
- 4. Conclude Activity** To conclude the activity, ask students the following questions:
 - ♦ Which recipe is easier to follow—the paragraphs on the board, or the numbered pictures and steps? Why?

Variation

Basic Review the text, paragraph by paragraph. Ask questions to make sure that students understand each step.

Advanced Have students write their own simple recipes for favorite foods. Tell them to list the ingredients at the top of the page and then list the steps in sequential order.

Name _____

Mix It!-Worksheet

Directions: These pictures are out of order. Cut out the pictures and put them in the correct order according to the recipe. Number each picture from 1 to 6, and then tell what to do on the lines below.

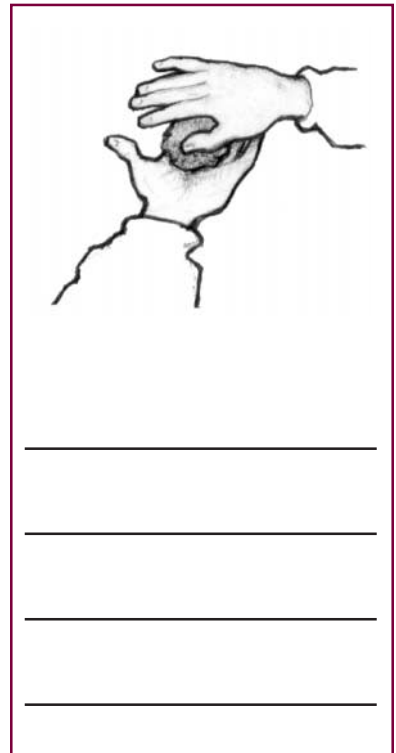
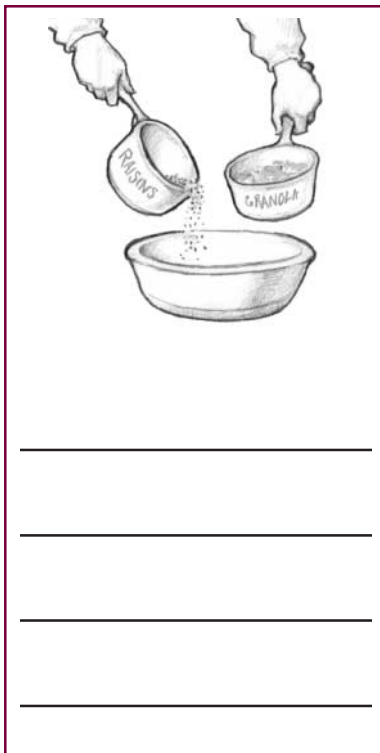
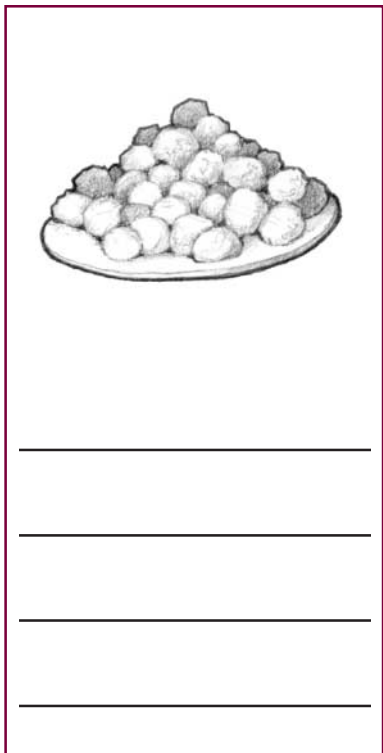
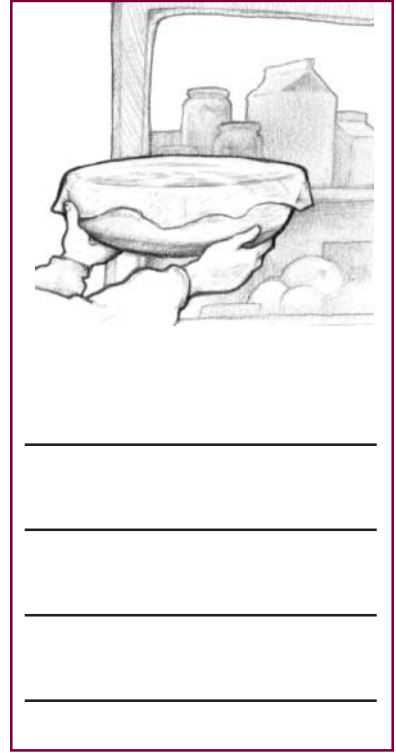
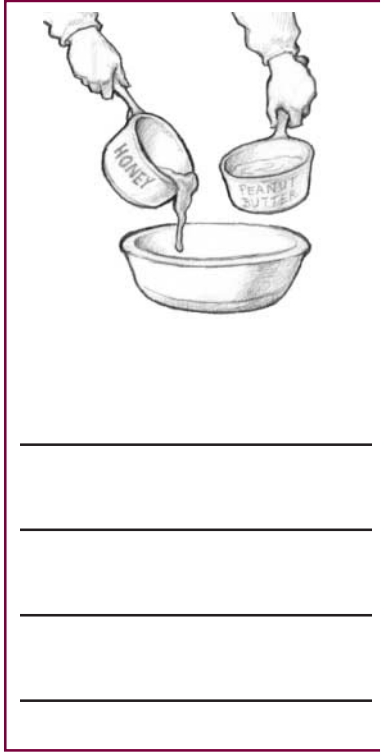

ACTIVITY

14

Where Are the Capital Letters?

- Purpose** In this activity, students show their understanding of when words should be capitalized.
Objective 09: Editing Skills **Thinking Skill:** Analyze Information
- Description** Students search for examples of capitalization in print, and record the words in a chart.
- Materials** a variety of magazines, books, and maps; overhead projector (optional)

Directions

- Getting Started** Explain that proper nouns are names of people, places, and things (including days, months, and holidays). Tell students that all proper nouns begin with capital letters. Words at the beginning of sentences should also be capitalized.
- Chart** On the board or overhead projector, draw a chart like the one shown below. Have students read the proper nouns in each column. Point out the use of capital letters.

Proper Nouns

Names	Places	Things
Alex	New York	Monday
Stuart Little	San Diego Zoo	Thanksgiving

- Word Search** Divide the class into small groups. Provide each group with magazines, books, maps, and other materials. Have each group search for proper nouns and create a list of words that must begin with capital letters. Have groups share their lists with the rest of the class.
- Worksheet** Distribute copies of the worksheet. Read the directions together. Tell students to rewrite the letter, capitalizing each word that needs a capital letter. Remind students that besides proper nouns, we also capitalize words at the beginning of sentences.
- Conclude Activity** Discuss the corrections that students made to the letter. Have volunteers write each part of the corrected letter on the board.

Variation

Basic Have students write or dictate their name, address, the name of their school, and a pet's name. Have them circle the capital letters they use.

Advanced Students can collect other examples of proper nouns, such as organizations, abbreviations, titles of people, historical events, team names, and proper adjectives (such as Labrador retriever or Swiss cheese).

ACTIVITY

15

Scavenger Hunt

Purpose

In this activity, students show their understanding of punctuation.
Objective 09: Editing Skills **Thinking Skill:** Analyze Information

Description

Students search for examples of punctuation marks in print—commas, apostrophes, question marks, periods, and exclamation points—and explain why they are used.

Materials

index cards for each student (optional)

Directions

- 1. Getting Started** Draw a large comma, apostrophe, question mark, period, and exclamation point on the board and ask students to identify each.
- 2. Punctuation Search** Divide the class into groups. Explain to students that they will go on a scavenger hunt for punctuation marks. Tell them they will look for examples in the classroom—on posters, in classroom writing, books, magazines, newspapers, and any other print materials.
- 3. Write Sentences** Distribute index cards (or pieces of paper) to each group. Tell students to write, on separate cards, each sentence they find during the scavenger hunt, and circle the punctuation marks used. Have students within each group take turns recording. After ten minutes, have students return to their seats and take turns reading aloud their examples.
- 4. Discuss** Keep track of the use of each punctuation mark by tallying the number of examples under each punctuation mark on the board. After each example is given, ask students to explain why the punctuation mark is used.
- 5. Conclude Activity** Repeat until all the different examples have been reported. Total the number of times each punctuation mark was used. Discuss which punctuation marks are used more or less frequently than others.

Variation

Basic Using each type of punctuation mark, write sentences on the board. Read aloud the sentence and explain why the mark is used. Then write another example without the punctuation mark and have students add it.

Advanced Challenge students to write a paragraph and use at least one example of each type of punctuation mark.

Mathematics

Teaching Activities

Activity Number and Title		<i>TerraNova, The Second Edition</i> Objective Number and Title	Activity Worksheet	Activity Page Number
1	Human Number Line	10 Number and Number Relations		7.38
2	Place Value Patterns	10 Number and Number Relations 16 Patterns, Functions, Algebra	X	7.39
3	Strategic Operations	11 Computation and Numerical Estimation	X	7.42
4	Token Target Game	11 Computation and Numerical Estimation		7.44
5	What's the Problem?	12 Operation Concepts	X	7.45
6	Daily Schedule	13 Measurement	X	7.48
7	Solid Shape Secrets	14 Geometry and Spatial Sense		7.51
8	Show-and-Tell Graphs	15 Data Analysis, Statistics, and Probability	X	7.52
9	What's in a Name?	15 Data Analysis, Statistics, and Probability		7.55
10	Pick a Pattern	16 Patterns, Functions, Algebra	X	7.56
11	Logic Riddles	17 Problem Solving and Reasoning		7.58
12	Time Capsule	13 Measurement 17 Problem Solving and Reasoning	X	7.59
Answers to Student Worksheets				7.94

ACTIVITY

1

Human Number Line

Purpose

This activity provides practice with comparing and ordering two-digit numbers.

Objective 10: Number and Number Relations **Thinking Skill:** Generate Ideas

Description

Using index cards, students compare and order two-digit numbers. They also form a “human number line.”

Materials

index cards, pre-made number lines on sentence strips or graph paper

Directions

- 1. Getting Started** Write a unique two-digit number on each index card, and give one card to each student. Group students into pairs. Give each pair of students one number line labeled from 0 to 100 at intervals of 10. If there is a large number line (labeled 0 to 100) displayed in your classroom, call attention to it.
- 2. Group Work** Have pairs of students use their number lines to determine where the number on each index card should be placed on the number line, and then decide whose number is greater. Have the students share with each other a reason they chose to place the numbers where they did.
- 3. Group Work** Have students work in groups of four. Ask each group to order their numbers from least to greatest on one number line. After students order the numbers, have them write or verbally express why they ordered the numbers the way they did.
- 4. Whole Class Activity** Have students make a “human number line” in the front of the classroom. Ask each group of four students to come to the front of the room and, one student at a time, display their index cards, and order themselves from least to greatest *without speaking*. When students are in order, invite the next group to come up and order themselves within the existing line at the front of the room, and so on, until all the students have ordered themselves from least to greatest.
- 5. Whole Class Activity** Have students announce their numbers, from the lowest to the highest. If any of them are out of order, have them switch places.
- 6. Conclude Activity** To conclude the activity, ask students the following question:
 - ♦ How did you know where to stand in the human number line?

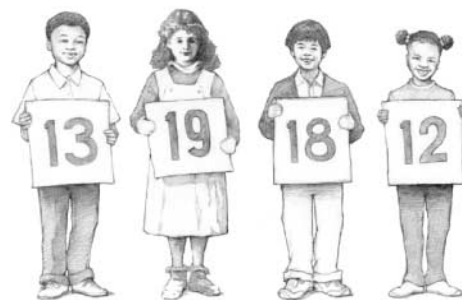
**Variation**

Basic Have students model and compare pairs of numbers with base ten blocks.

Advanced Complete the number line placement activity as described above, using pictures, drawings, or names of things you might buy at a toy store and prices you assign to them. Limit the upper range to amounts you think are appropriate for your class.

ACTIVITY

2

Place Value Patterns

Purpose

This activity provides practice with number patterns using 3-digit numbers.

Objective 10: Number and Number Relations **Objective 16:** Patterns, Functions, Algebra

Thinking Skill: Analyze Information

Description

Students use base ten blocks to build place value concepts and to identify, continue, and extend patterns.

Materials

base ten blocks (or other appropriate place value manipulatives), one-inch (or larger) grid paper for each student

Directions

- 1. Getting Started** Pass out the grid paper and tell students that they will be making a number chart together. Using base ten blocks, display 3 hundreds, 4 tens, and 6 ones. Align the blocks in place value columns. Ask students to name the number represented by the blocks (346). Write the result on the board and have students write it in a center block on their grid paper. Add one block to the ones column, ask students to name the new number (347), and write it to the right of 346. Then subtract 2 blocks from the ones column, ask students to name the new number (345), and write it to the left of 346.
- 2. Repeat** Repeat the procedure, beginning with 346, and add one tens block to the tens column and have the students write the new number (356) below the original number. Then take away 2 tens blocks from the tens column and have students write the new number (336) above the original number.
- 3. Whole Class Activity** From 336 on, tell students *as you do it* that you are adding to or taking away 1 block from the ones or tens column. Ask a volunteer to name each new number and describe its location on the number chart. Then have all the students add the number to their charts. A completed number chart may look like this:

335	336	337	338	339
345	346	347	348	349
355	356	357	358	359
365	366	367	368	369

- 4. Discussion** Invite students to extend the patterns they see. Ask questions such as:
 - ♦ What number would be directly above 339? (329)
 - ♦ Did you use the ones or the tens place to figure this out?
- 5. Repeat** Repeat Steps 1 through 3, beginning with 457. Build numbers that are 10 more, 10 less, 100 more, and 100 less. Record numbers that are 10 more or 10 less horizontally, and 100 more or 100 less vertically. Ask students what place value changes they are making each time they come up with a new number.
- 6. Conclude Activity** To conclude the activity, ask students the following questions about each chart:
 - ♦ How do the numbers change in the ones and tens places when you increase the ones?
 - ♦ How do the numbers change in the ones and tens places when you decrease the ones?
 - ♦ How do the numbers change in the ones and tens places when you increase the tens?
 - ♦ How do the numbers change in the ones and tens places when you decrease the tens?

Students may use the worksheet to practice their skills.

Variation

Basic Complete the activity using two-digit numbers. Use a hundreds chart to help.

Advanced Complete the activity using four-digit numbers. Have students find numbers that are 100 more or less than a number and 1,000 more or less than a number.

Name _____

Place Value Patterns–Worksheet

Directions: Write a number in each box to complete each chart.

1

233	234	235		
243		245	246	
			256	257

2

565				
	576			579
	586	587		
		597	598	

3

		251		
		261	262	
269				
				283

4

			435	
	443	444		

ACTIVITY

3

Strategic Operations

Purpose

In this activity, students create and solve computation problems.

Objective 11: Computation and Numerical Estimation **Thinking Skill:** Evaluate Outcomes

Description

Students find sums and differences using assorted materials.

Materials

counters, pre-made number lines, index cards, colored pencils or crayons (red, blue, purple, brown, green, yellow, and orange)

Directions

- 1. Getting Started** Give each group of four students counters and number lines. Write $9 + 5 = \underline{\quad}$ on the board. Have students name the strategies they might use to find the sum. List responses on the board, which may include: *use counters, use a number line, count on, regroup after 10, or use mental math.*

Have groups “prove” that $9 + 5 = 14$, using each strategy listed. Emphasize that the sum is the same regardless of the strategy used.
- 2. Group Work** Provide each group with index cards, numbered 1 through 25. The cards should not be in numerical order. One student picks two cards in a row to make an addition problem. All four students choose a strategy from Step 1 for finding the sum. Once everyone finds the sum, students share their solution strategies. Play continues for three more rounds.
- 3. Discussion** On the board, write $17 - 8 = \underline{\quad}$ and ask students to solve the problem. List the responses on the board.
- 4. Group Work** Have students use their number cards and repeat the process used in Step 2, only this time, have them create and solve *subtraction* problems using the strategies given in Step 1. Some students may continue work with basic facts; others may solve two-digit sums and differences or add groups of three or more numbers.
- 5. Conclude Activity** To conclude the activity, ask students the following questions:
 - ♦ How did you decide which way to solve each problem?
 - ♦ Did you use one way more than any other?
 - ♦ If so, which one was it? Why did you choose it?
 Students may use the worksheet to practice their skills.

Variation

Basic Review strategies for finding sums and differences, such as counting on or back, using doubles, regrouping, and so on.

Advanced For each strategy listed, have students generate their own list of problems they could solve using that strategy.

Name _____

Strategic Operations–Worksheet

Directions: Find each sum or difference. Color the box to show how you got your answer.

RED: I used a number line.	GREEN: I used counters.
BLUE: I used mental math.	YELLOW: I counted on or back.
PURPLE: I used pencil and paper.	ORANGE: I used regrouping.
BROWN: I used my own way.	

$28 + 6 = \underline{\quad}$	$24 + 19 = \underline{\quad}$	$55 - 8 = \underline{\quad}$	$11 - 4 = \underline{\quad}$
$6 + 9 = \underline{\quad}$	$18 - 6 = \underline{\quad}$	$13 + 5 = \underline{\quad}$	$48 - 9 = \underline{\quad}$
$16 + 63 = \underline{\quad}$	$52 + 17 = \underline{\quad}$	$40 + 48 = \underline{\quad}$	$15 - 9 = \underline{\quad}$
$35 - 19 = \underline{\quad}$	$47 - 34 = \underline{\quad}$	$81 + 13 = \underline{\quad}$	$57 - 7 = \underline{\quad}$
$12 + 13 = \underline{\quad}$	$18 - 12 = \underline{\quad}$	$64 - 39 = \underline{\quad}$	$47 + 48 = \underline{\quad}$
$50 + 7 = \underline{\quad}$	$13 - 7 = \underline{\quad}$	$16 - 7 = \underline{\quad}$	$32 - 16 = \underline{\quad}$
$19 + 15 = \underline{\quad}$	$11 + 5 = \underline{\quad}$	$46 + 33 = \underline{\quad}$	$29 + 8 = \underline{\quad}$
$44 - 8 = \underline{\quad}$	$8 + 11 = \underline{\quad}$	$4 + 75 = \underline{\quad}$	$17 - 8 = \underline{\quad}$

ACTIVITY

4

Token Target Game

Purpose

This activity provides practice in estimation as students create and solve addition and “missing addend” number sentences.

Objective 11: Computation and Numerical Estimation **Thinking Skill:** Organize Information

Description

Students combine different numbers of tokens to arrive at a target amount.

Materials

various classroom objects affixed with tags showing the number of tokens each item costs

Directions

- 1. Getting Started** Tag classroom objects with two-digit amounts of tokens, as shown below. Make sure that some amounts can be easily used to practice estimation and mental math.

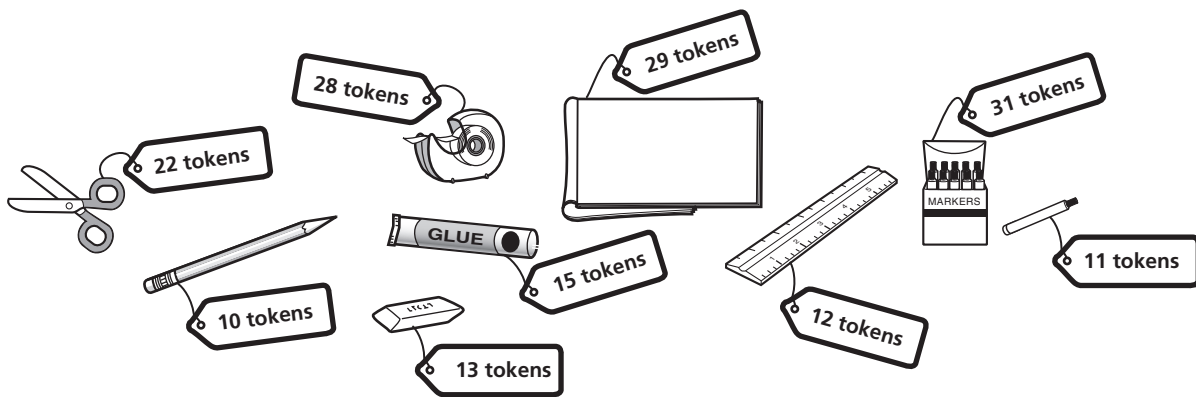

- 2. Group Work** Arrange students into teams of four players. Give teams one target amount, such as 50 tokens. Challenge teams to identify and list two to four items that can be purchased for close to the target amount. Explain that at this point you want teams to make lists of items costing close to 50 tokens, but no more than 15 tokens over or under 50. Encourage students to use estimation and mental math to arrive in the target token range. Play additional rounds, using a different target amount each time.
- 3. Explain** Make the activity harder by telling students that the first team to come as close as possible to the target amount *without going over* wins the round.
- 4. Conclude Activity** To conclude the activity, ask students the following questions:
 - ♦ What strategies did you use to find items for the target token amount?
 - ♦ How did estimation help you?
 - ♦ How did mental math help?

Students may find that there are several possible lists of items with the same target amount.

Variation

Basic Have students use base ten blocks to model and combine amounts.

Advanced Complete the activity as described above using a mix of two- and three-digit token amounts.

ACTIVITY

5

What's the Problem?

- Purpose** This activity provides practice in modeling, solving, and writing real-life word problems.
Objective 12: Operation Concepts **Thinking Skill:** Gather Information
- Description** Students connect operations with their uses in real-life problems.
- Materials** base ten blocks (or appropriate counting manipulatives)

Directions

- Getting Started** Tell students that there are many ways to tell a story. Most stories, however, have a problem and a solution. Then tell students that word problems in math tell stories too. They have a problem and a solution *in numbers*.
- Explain and Discuss** Have students form groups of three. Give base ten blocks to each group. Tell students to listen as you read each of the following stories to the class:
 - ◆ Mike found 18 seashells on the beach. He found another 15 shells near his beach cottage. How many seashells did Mike find in all?
 - ◆ A photographer took 36 pictures of Mike with his family. Mike's family bought 12 of the pictures. How many are left?
 After each story is read, solve the problems together. Have a student from each group explain how each problem was solved.
- Group Work** Give each group of students an addition or subtraction number sentence, such as $32 + 17 = \underline{\quad}$ or $58 - 39 = \underline{\quad}$. Have students work together to write a story problem that matches the number sentence, solve the problem with blocks (or play money if appropriate), and write the solution.

$$32 + 17 = 49$$

Sam had 32 stickers.

He bought 17 more stickers.

How many stickers does he have in all?

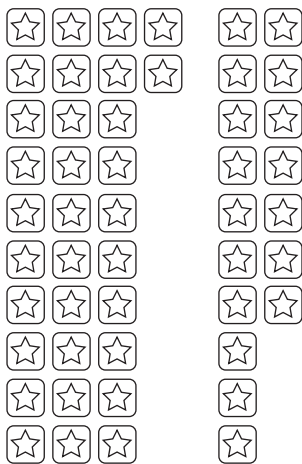

- Conclude Activity** Have one group share their story problem with the rest of the class. Invite classmates to say what number sentence could be used to solve the problem, and find the solution.

Ask students the following question about the problem:

- ◆ What words in the problem helped you know whether to add or subtract?

Repeat this process with each of the other groups. Students may use the worksheet to practice their skills.

Variation

Basic Review the key words associated with addition and subtraction word problems. Have students solve problems using number sentences with sums to 18.

Advanced Challenge students to write and solve problems using amounts over 100.

Name _____

What's the Problem?—Worksheet

Directions: Use the bowling scores listed here to write a number sentence that will help you solve each problem below. The first one has been done for you.

	Brandon	Belinda	Don	Carmen
Game 1	32	45	46	42
Game 2	48	48	41	50

- 1** What was Brandon's total score for both games?

$$\underline{32 + 48 = 80}$$

Brandon's total score was 80.

- 2** What was Belinda's total score for both games?

Belinda's total score was _____.

- 3** By how many points did Don beat Belinda in the first game?

Don beat Belinda by _____ point(s) in the first game.

- 4** By how many points did Carmen beat Brandon in the second game?

Carmen beat Brandon by _____ point(s) in the second game.

- 5** How many more points did Brandon score in the second game than in the first?

Brandon scored _____ more point(s) in the second game than in the first.

- 6** How many more points did Carmen score in the second game than in the first?

Carmen scored _____ more point(s) in the second game than in the first.

- 7** On the back of this sheet, write and solve your own story problem based on the bowling scores.

ACTIVITY

6

Daily Schedule

Purpose

In this activity, the students measure time.

Objective 13: Measurement **Thinking Skill:** Analyze Information

Description

Students find the amount of time they spend on daily activities at school.

Materials

large clock with hands that can be moved by students, an easily seen schedule of the day's events or lessons posted (Make time intervals between scheduled events an appropriate length and level of difficulty for problem solving by your students.)

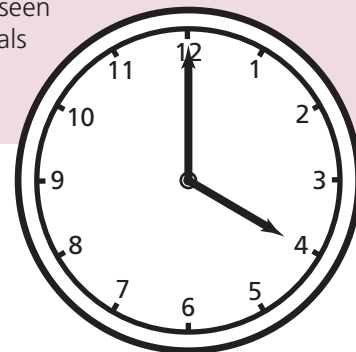
**Directions**

- 1. Getting Started** Display a clock, with moveable hands, that is big enough for the whole class to see. If available, distribute individual clocks to each student. Post a class schedule. Have students as a group read aloud the day's activities and their starting times.
- 2. Whole Class Activity** Invite a *time setter* volunteer to set the large clock to the time shown for the first activity. Invite a *scheduler* volunteer to point to the spot on the schedule that shows the starting time of the second event or activity. Ask the class how they could use the clock to find the amount of time between the beginning of the first and second activities. Have the *time setter* move the hands of the clock as the class suggests. If students have individual clocks, they may move the clock's hands similarly. Have students find the elapsed time between the first and second activities by counting (in 1-minute, 5-minute, or 15-minute intervals) the number of minutes the minute hand was moved from the starting time of the first activity to the starting time of the second activity.
- 3. Repeat** Select a new *time setter* and *scheduler*. Repeat the procedure in Step 2 for the remaining activities on the schedule.
- 4. Conclude Activity** To conclude the activity, ask students the following questions:
 - ♦ How did the clock help you find the time spent on different activities?
 - ♦ Which hand did you move first?

Students may use the worksheet to practice their skills.

Variation

Basic Have students review telling time to the hour, half-hour, quarter-hour, and 5 minutes using the display clock or their own individual clocks.

Advanced Invite students to find the elapsed time of combined events, such as the time between the start of the school day and lunch, or the beginning and end of a school day.

Name _____

Daily Schedule-Worksheet

Directions: Fill in the blanks to complete each story. Use hours and minutes.
The first one has been done for you.

1 Mom put the turkey in
the oven at 2:00.



The turkey cooked for 4 hours.

Mom took the turkey out
of the oven at 6:00.

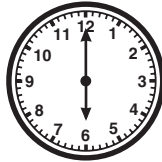

2 The soccer game begins
at _____.



The soccer game lasts for _____.

The soccer game ends
at _____.

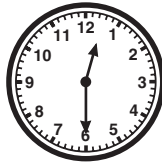

3 School begins
at _____.



School lasts for _____.

School ends
at _____.



Name _____

Daily Schedule-Worksheet continued

4 Ryan went to sleep

at _____.



Ryan woke up

at _____.



Ryan slept for _____.

5 Simon's music lesson

begins at _____.



Simon's music lesson

ends at _____.



Simon's music lesson lasts

for _____.

ACTIVITY

7

Solid Shape Secrets

Purpose

This activity provides practice in identifying and describing characteristics of geometric solids.

Objective 14: Geometry and Spatial Sense **Thinking Skill:** Gather Information

Description

Students describe solid shapes by their unique characteristics.

Materials

a set of geometric solids (or appropriately shaped objects),
paper bag

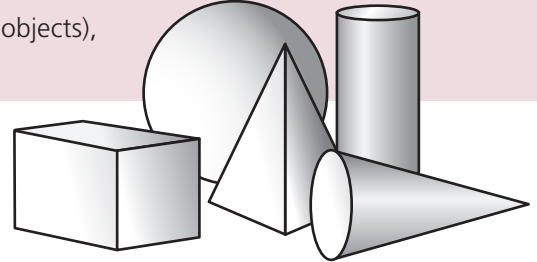
**Directions**

- 1. Getting Started** Display a group of geometric solids at the front of the room. If geometric solids are unavailable, obtain a collection of everyday objects such as dice, paper cones, cans, boxes, and so on. Review with students the words used to describe solids: *faces*, *edges*, *corners*.
- 2. Discussion** Focus students' attention on one geometric solid at a time, having them name the solid's attributes and characteristics. For example, students may say that a cylinder has two circular faces, can be rolled, can be stacked, and has no corners.
- 3. Whole Class Activity** Move the solids so they are not in sight. Place one solid in a brown paper bag. Invite a volunteer to reach inside the bag, feel the solid, and describe it to the class *without stating its name*.
- 4. Discussion** Invite students to say what the geometric solid inside the bag is, based on the description given and the questions answered. Finally, invite the volunteer to pull the geometric solid out of the bag and show it to the class.
- 5. Repeat** Repeat the activity as time permits.
- 6. Conclude Activity** To conclude the activity, ask students the following question:
 - ♦ A cube is a special kind of rectangular prism. What makes the cube different from other kinds of rectangular prisms? (It has 6 sides all the same size.)

Variation

Basic Have students compare plane shapes.

Advanced Have students write and share riddles about solid shapes.

For example: "I am often a box. If I am standing around for a long time and blow my top, you can still see five of my faces." (a rectangular solid)

ACTIVITY

8

Show-and-Tell Graphs

Purpose

This activity provides practice in constructing and analyzing a pictograph.

Objective 15: Data Analysis, Statistics, and Probability **Thinking Skill:** Generate Ideas

Description

Students create and analyze a pictograph made from classroom items.



Materials

various drawing tools, one bag for each group of four students, drawing paper

Directions

- Getting Started** Arrange students in groups of four. Tell the groups that they will be making a pictograph about drawing tools. Distribute a bag containing varying amounts of drawing tools to each group. For example, give group one 2 pencils, 6 erasers, and 3 sheets of paper. Give group two 4 pencils, 2 erasers, and 2 sheets of paper, and so on.
- Group Work** Create a pictograph template on the board, including labels, based on the pictograph shown below. Distribute drawing paper and have students draw their own pictograph templates, one per group. Have students count their drawing tools and draw them on the graph.

Drawing Tools

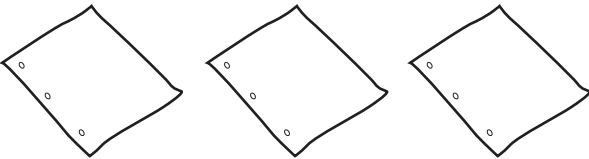
Pencils	
Erasers	
Sheets of paper	

- Discussion** Invite one group to show their pictograph. Have the group describe the graph to the rest of the class by answering questions such as the following:
 - ♦ Which drawing tools do you have the most of? the least?
 - ♦ How many items are there in all? How do you know?

Instruct students to place the pictograph in an easy-to-see location.

- Discussion** Have other groups show their graphs using similar questioning. Make sure students understand that the pictographs help them see and count the items in an organized way.
- Conclude Activity** To conclude the activity, ask students the following questions:
 - ♦ How are all these graphs alike? How are they different?
 - ♦ How many pencils are there on all the graphs combined? how many erasers? how many sheets of paper?

Students may use the worksheet to practice their skills.

Variation

Basic Have students focus on one single pictograph. Invite them to touch and count each item to find the amounts shown.

Advanced Challenge students to create a pictograph showing other classroom tools, such as clips, glue sticks, and tape. This time, have them sketch their own graph and write a paragraph describing it. You may even want to have students use one symbol to stand for two of each item. (In this case, students would need to draw a key to indicate how many of each item the symbol represents.)

Name _____

Show and Tell Graphs-Worksheet

Directions: Use the information in the graph to answer the questions.

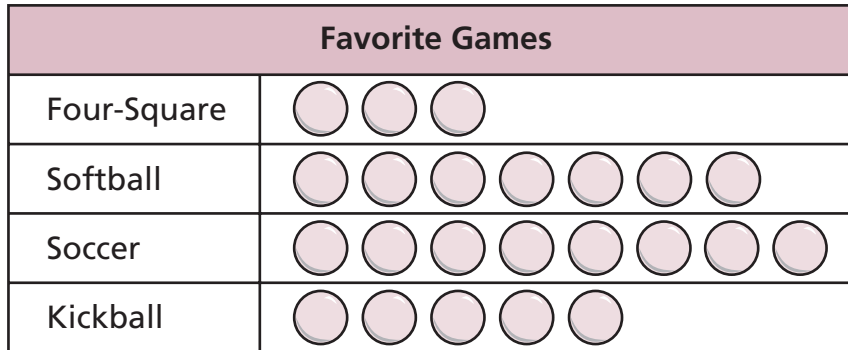

KEY
 = 1 student

- 1** How many students like softball best? _____
- 2** How many students like kickball best? _____
- 3** How many more students chose soccer than four-square? _____
- 4** How many more students chose soccer than softball? _____
- 5** How many fewer students chose kickball than softball? _____
- 6** How many fewer students chose four-square than kickball? _____
- 7** How many students chose either kickball or softball? _____
- 8** How many students chose either soccer or four-square? _____
- 9** How many students voted in the "Favorite Games" survey? _____

ACTIVITY



What's in a Name?

Purpose

This activity provides practice in constructing a bar graph and analyzing trends.

Objective 15: Data Analysis, Statistics, and Probability

Thinking Skills: Gather, Organize, Analyze Information

Description

Students create a bar graph and then analyze its data for trends.

Directions

- Getting Started** On the board, draw a large bar graph titled “Letters in Our First Names.” Invite volunteers to help you label the graph’s axes: one axis for “Number of Letters in a Name” (with specific rows or columns labeled for the values 1, 2, 3, 4, 5, 6, 7, 8, and *more than 8*) and one axis for “Number of Student Names” (with a numeric scale from 0 to 10 marked at intervals of one).
- Whole Class Activity** Invite one student at a time to call out the number of letters in his or her name as you list the number on the board and record it on the bar graph. (If time permits, you may wish to have students fill in the graph segments.)
- Discussion** With the class, discuss the results of the bar graph. Ask the class how many students’ names have 1, 2, 3, 4, 5, 6, 7, 8, and more than eight letters.
An example of a completed “Letters in Our First Names” bar graph is shown below. (Results for each class will vary.)

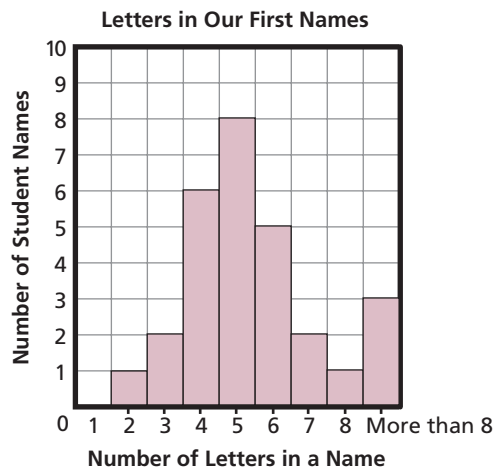

- Conclude Activity** To conclude the activity, ask students the following questions:
 - ♦ What number of letters did the greatest number of students have? the fewest?
 - ♦ What else do you know about the number of letters shown in the graph?
 Evaluate the bar graph for trends by asking the following question:
 - ♦ What pattern do you see in the letters of the students’ names?

Variation

Basic Have students analyze the bar graph without evaluating trends. Ask students to tell the greatest and fewest number of names, compare the number of 5-letter names with the number of 7-letter names, and so on.

Advanced Challenge students to predict what would happen if they created a bar graph for the number of letters in the first names of their families and friends. Then have them create the bar graph to check their predictions.

ACTIVITY

10

Pick a Pattern

Purpose	This activity provides practice with recognizing and continuing number patterns. Objective 16: Patterns, Functions, Algebra Thinking Skill: Evaluate Outcomes
Description	Students identify, describe, and extend number patterns.
Materials	blocks or cubes, crayons or colored pencils

Directions

- 1. Getting Started** Write the sequence 2, 4, 6, 8, —, —, — on the board. Have students work in pairs, using blocks or cubes to model each number in the pattern, and then identify the next numbers in the pattern.
- 2. Discussion** Have students tell how they continue the pattern. Encourage students to look for other ways to describe the characteristics of the numbers in the pattern. For example, students may say that the numbers are all even, that they increase by two, that they are every other (counting) number, and so on.
- 3. Repeat** Repeat the procedure outlined in Step 1 for several other simple patterns. Patterns may include, but need not be limited to, the following:
 - 10, 20, 30, 40, —, —, —
 - 5, 10, 15, 20, —, —, —
 - 3, 13, 23, 33, —, —, —
 - 11, 22, 33, 44, —, —, —
- 4. Whole Class Activity** Have students make up patterns by writing the first four numbers. Then have them draw three blank lines for the next three numbers. Invite volunteers to share their patterns with the class and challenge classmates to identify, describe, and continue each other's patterns.
- 5. Conclude Activity** To conclude the activity, ask students the following questions:
 - ♦ How do you make a pattern?
 - ♦ How do you find out what will come next in any pattern?
 Students may use the worksheet to practice their skills.

Variation

Basic Ask students to identify and describe simple patterns (such as 0, 2, 4, 6, 8, or 10, 20, 30, 40, . . .). Once students are comfortable with pattern identification, move on to naming subsequent numbers in a pattern.

Advanced Have students identify and extend more complex patterns, such as 28, 24, 20, 16, 12, 8 or 10, 18, 26, 34, 42, 50.

Name _____

Pick a Pattern–Worksheet

Directions: Circle the number 2. Then circle every second number. Color the number 3. Then color every third number.

1	2	3	4	5	6	7	8	9	10
11	12	13	14	15	16	17	18	19	20
21	22	23	24	25	26	27	28	29	30
31	32	33	34	35	36	37	38	39	40
41	42	43	44	45	46	47	48	49	50
51	52	53	54	55	56	57	58	59	60
61	62	63	64	65	66	67	68	69	70
71	72	73	74	75	76	77	78	79	80
81	82	83	84	85	86	87	88	89	90
91	92	93	94	95	96	97	98	99	100

1 What number can you count by to find all the even numbers?

2 What are the first 10 numbers that you colored?

3 What are the first 10 numbers that are both colored **and** circled?

4 On the lines below, describe the pattern that you see in your answer to question 3.

ACTIVITY

11

Logic Riddles

Purpose

This activity provides practice using deductive reasoning to solve problems.

Objective 17: Problem Solving and Reasoning **Thinking Skill:** Analyze Information

Description

Students use logical reasoning to solve number riddles.

Directions**1. Getting Started** Write the following riddle on the board:

- ♦ I am a number between 16 and 30. You say me when you count by 5s. I am greater than 20. What number am I?

2. Discussion Encourage students to use a hundred square or a number line to identify the numbers between 16 and 30. Ask students the following question:

- ♦ Can the number be between 1 and 15? (no)

List the numbers 16 to 30 on the board. Point out that the number is between 16 and 30, so it cannot be either number. Cross out 16 and 30. Ask the class to count by fives from 0 to 30. Ask a volunteer to circle on the board the numbers that have been said out loud. Ask students the following question:

- ♦ Which of the circled numbers is greater than 20? (25)

Help students deduce that the number that satisfies all the clues in the riddle is 25. An example of what should be written on the board is shown below.

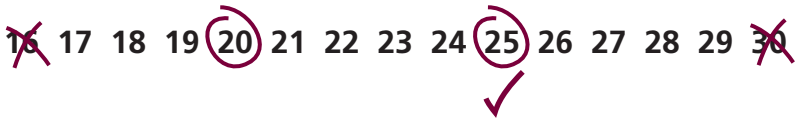
~~16~~ 17 18 19 (20) 21 22 23 24 (25) 26 27 28 29 ~~30~~

3. Repeat Repeat the procedure outlined above for other number riddles, such as the following:

- ♦ I am an odd number between 19 and 25. I am greater than 21 and less than 24. What number am I? (23)
- ♦ I am an odd number between 40 and 60. I have the same number of tens and ones. What number am I? (55)
- ♦ I am a number between 20 and 30. The sum of my ones number and tens number is 8 and the difference is 4. What number am I? (26)
- ♦ I am an even number between 50 and 70. I have the same number of tens and ones. What number am I? (66)

You can do some of these riddles as a class and have students do the rest independently or in pairs. If time allows, try the Advanced activity described below, with all students.

4. Conclude Activity To conclude the activity, ask students the following question:

- ♦ What are some of the ways you tried to solve the number riddles?

Variation

Basic Provide students with similar riddles for numbers between 1 and 10.

Advanced Invite students to write their own number riddles and challenge their classmates to solve them. Have students start to make a riddle by thinking of a number and then finding what its properties are—odd, even, greater than or less than another number, part of a pattern, etc.

ACTIVITY

12

Time Capsule

Purpose

This activity provides practice in solving measurement problems.

Objective 13: Measurement **Objective 17:** Problem Solving and Reasoning

Thinking Skill: Evaluate Outcomes

Description

Students use a ruler to measure items for a time capsule.

Materials

rulers, paper clips, crayons, and various classroom items

Directions

- 1. Getting Started** Distribute a ruler to each student. If necessary, review the procedure for using a ruler to measure an object. Rulers may differ in their configurations.
- 2. Whole Class Activity** Have students measure a paper clip and a new crayon. Verify that the paper clip is about 1 inch long and that the crayon is about 4 inches long. Point out that if a measurement falls between two inch marks, they should measure the item to the nearest half-inch mark.
- 3. Direct Instruction** Tell students that the class is filling a time capsule with items that measure at least 3 inches but no more than 5 inches. Direct the class to find, in the classroom, as many items as possible that fit these lengths. Students will use rulers to measure each item and make tables (on their own individual sheets of paper) listing the items, their lengths, and whether or not they belong in the time capsule. A partially completed table is shown below.

Item	Length	Time Capsule Item?
Marker	5 inches	Yes
New Pencil	7 inches	No
Scissors		
Glue Stick		

- 4. Conclude Activity** To conclude the activity, ask students the following questions:
 - ♦ How did you decide which items to measure?
 - ♦ Were the items that didn't fit into the time capsule too long or too short? Were they far off?
 Students may use the worksheet to practice their skills.

Variation

Basic Review the procedure for measuring to the nearest half-inch. Have students draw lines of a specified length. Check students' work.

Advanced Have students measure the distance around a book. Show them how to add the four sides to find the book's perimeter. Repeat for other plane items found in the classroom.

Name _____

Time Capsule-Worksheet

Directions: Use the inch side of your ruler to measure each line in the house. Write the measurements in the table.

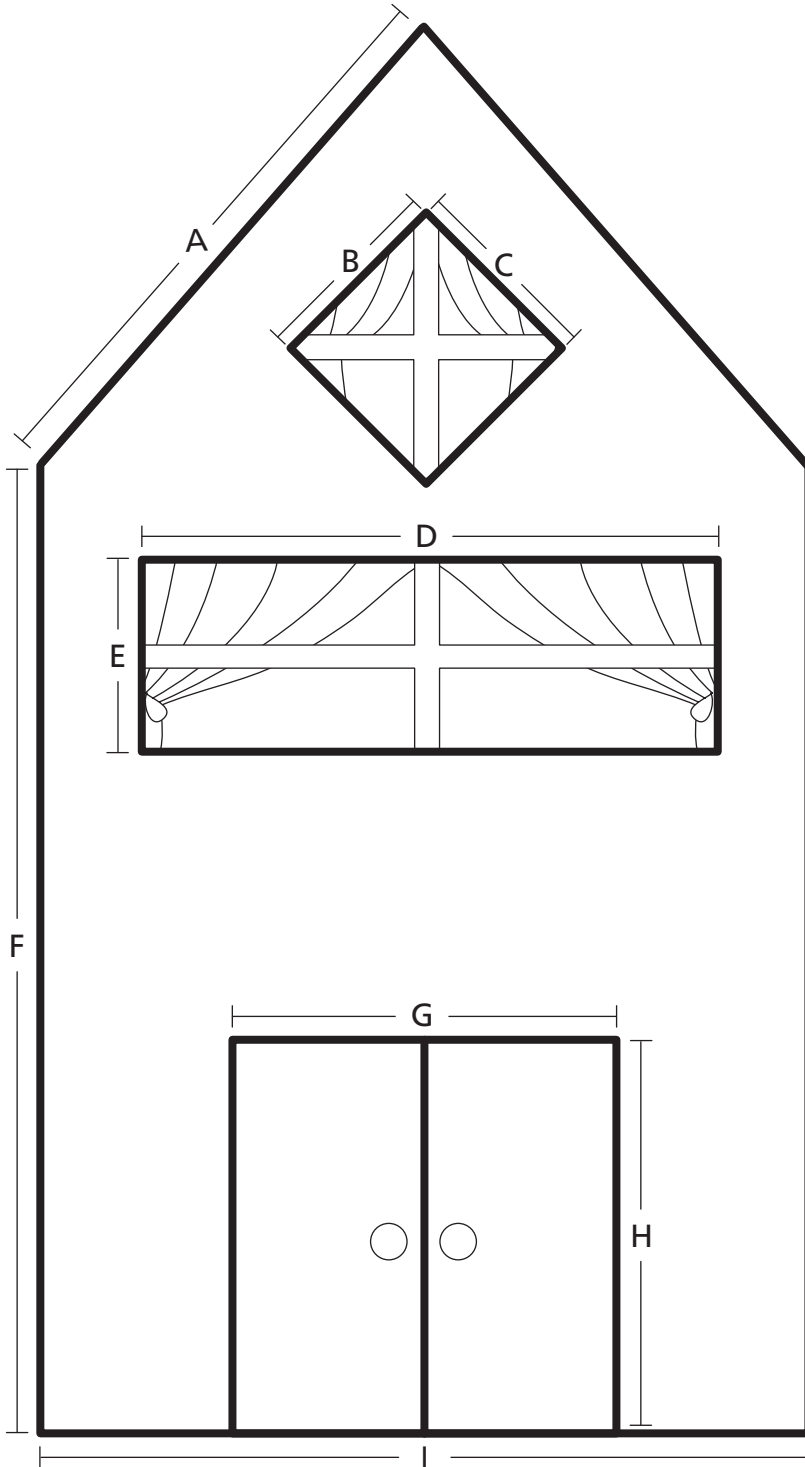

Line	Length (in inches)
A	
B	
C	
D	
E	
F	
G	
H	
I	

Science

Teaching Activities

Activity Number and Title		<i>TerraNova, The Second Edition</i> Objective Number and Title	Activity Worksheet	Activity Page Number
1	Insect Life Cycles	21 Life Science	X	7.62
2	Name That Tree	19 Science Inquiry 21 Life Science	X	7.65
3	A Home Makes a Habitat	21 Life Science 24 Personal and Social Perspectives in Science	X	7.67
4	Comparing Weights	19 Science Inquiry 20 Physical Science	X	7.69
5	Physical Properties of Objects	19 Science Inquiry 20 Physical Science		7.71
6	How Well Does It Float?	20 Physical Science 23 Science and Technology		7.72
7	Our Closest Neighbor in Space	22 Earth and Space Science 23 Science and Technology	X	7.73
8	The Water Cycle and Acid Rain	22 Earth and Space Science 24 Personal and Social Perspectives in Science	X	7.75
Answers to Student Worksheets				7.95

ACTIVITY

1

Insect Life Cycles

Purpose

In this activity, students will learn about the life cycles of insects.

Objective 21: Life Science **Thinking Skills:** Organize Information; Synthesize Elements

Description

Students determine the correct sequence of the butterfly's life cycle. They also compare pictures of the life cycle of a cricket with that of a butterfly, in order to understand that not all insects have the same life cycle.

Directions

- 1. Getting Started** Distribute copies of Worksheet 1. Read the story "The Life Cycle of a Butterfly" aloud to the students as the basis for a discussion about metamorphosis.
- 2. Worksheet** Explain to students that the pictures they are about to look at show the life cycle of a butterfly, but they are out of order. Distribute copies of Worksheet 2. Have students refer to the text and then put the pictures in correct order by numbering them from 1 to 4. Then ask:
 - ♦ In what ways is a caterpillar different from a butterfly?
 - ♦ Why does a caterpillar need to become a pupa in order to change into a butterfly?
- 3. Look and Ask** Have students look at the three pictures of the life cycle of a cricket. Ask the following question and have students write their answers on the bottom of Worksheet 2:
 - ♦ In what ways is the life cycle of a cricket different from the life cycle of a butterfly? (A baby cricket looks like an adult cricket. It does not become a pupa.)
- 4. Conclude Activity** Ask students to think about other animals.
 - ♦ Which animals have life cycles in which the babies look like their mothers and fathers? (cats, dogs, fish, horses, monkeys, etc.)
 - ♦ Which animals do not? (frogs, toads, flies, moths, etc.)

**Variation**

Have the students complete Story 2, "The Life Cycle of a Cricket."

Introduce new terms:

Complete metamorphosis: the four-stage life cycle of a butterfly

Chrysalis: the specific term for the butterfly pupa

Nymph: a young cricket

Name _____

Insect Life Cycles-Worksheet 1

Story 1: The Life Cycle of a Butterfly

Have you ever seen a baby chicken hatch from an egg? When a baby chicken hatches from its egg, it looks like a little chicken. It stands on two legs, has wings, and is covered with feathers. It is much smaller than its mother and father, but it looks similar to them.



When baby butterflies hatch from their eggs, they don't look anything like their parents. When a mother butterfly lays an egg, a caterpillar hatches. The caterpillar eats and eats. It grows and grows. Soon, it stops eating and makes a covering around itself. The caterpillar is now called a pupa.

While it is a pupa, the baby butterfly sleeps. It is getting a new body and slowly starts turning into a grown-up butterfly. It grows wings and gets ready to go back out into the world.

Finally, its big day comes and it breaks out of its covering. It is now an adult butterfly. It stays still while its wings dry. Then it flies away to join other butterflies.

Story 2: The Life Cycle of a Cricket

A mother cricket lays an egg. When it hatches, _____

Name _____

Insect Life Cycles-Worksheet 2

The Life Cycle of a Butterfly

Directions: These pictures show a butterfly's life cycle. They are out of order. Put them in the correct order, starting with the egg, by numbering them from 1 to 4.

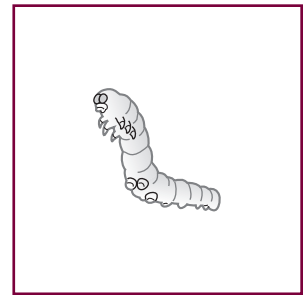
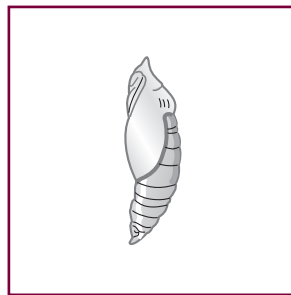
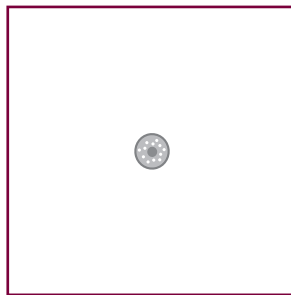
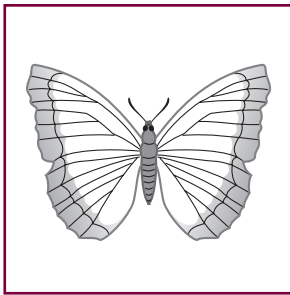



The Life Cycle of a Cricket

Directions: These pictures show the life cycle of a cricket. How is its life cycle different from the life cycle of a butterfly? Write your answer on the lines below.



1



2



3

ACTIVITY

2

Name That Tree

Purpose

In this activity, students will learn to identify a tree from pictures of its parts.

Objective 21: Life Science **Objective 19:** Science Inquiry

Thinking Skill: Synthesize Elements

Description

Using pictures of parts of two distinctly different trees, students will identify the trees while on a nature walk.

Preparation

Scout out the immediate area around the school or another convenient place where you can take students on a science walk. There should be at least three distinctly different kinds of trees that students can identify.

Directions

- 1. Getting Started** In class, introduce the concept that plants—including trees—have specific names that help people tell them apart from similar kinds of plants. Brainstorm with students and come up with a list of tree names they know—for example, oak, maple, pine, palm.
- 2. Show and Explain** Explain to students that different trees have different kinds of leaves, flowers, bark, and fruit—as well as different shapes and trunks. These differences can help people distinguish one type of tree from another. Show pictures of three parts of each tree that the students will identify on their walk.
- 3. Worksheet** Hand out copies of the worksheet. Have students choose one of the trees you have shown them and have them draw three different parts of that tree in the spaces provided on the worksheet (Part 1). Each drawing should be accompanied by a description of the part of the tree drawn. For example, if students choose an oak tree, they might draw a picture of a leaf, an acorn, and the trunk. They should then write a short description underneath each part. Observe students as they make their drawings and notes, and help them as needed.
- 4. Identify and Record** Take students on a walk. Students should bring their drawings and notes. Stop in front of the first tree you would like them to identify. Ask them to compare the tree parts they have drawn with the parts of the actual tree. Ask for a volunteer to name the tree. Ask students to describe the different parts of the tree. Repeat this procedure with the second tree.
- 5. Conclude Activity** Ask students the following question:
 - ♦ Are any of the trees near your home the same as the ones you saw on the nature walk?



Variation

Have students sketch tree parts from an additional tree that you pass on your walk (Part 3). Back in class, have students see if they can find their tree in a book used to identify trees.

Name _____

Name That Tree-Worksheet

Part 1 Do in class.

Directions: Choose a tree and draw three of its parts in the boxes below. Be sure that all three pictures are of different parts of the same kind of tree. Write the name of the tree. On the lines below your drawings, describe each tree part.

Name of tree _____



Part 2 Go outside on a nature walk.

Directions: At each stop, compare a tree part with your drawing of that part. If it matches, compare the other tree parts with your drawings. If they match, say the name of that tree when the teacher asks for it.

Part 3 Start outside and finish in class.

Directions: Draw two or three parts of a different kind of tree that you have seen on your nature walk. When you return to class, see if you can find the name of the tree in a book, using your drawings as a guide.



Name of tree _____

ACTIVITY

3

A Home Makes a Habitat

Purpose

In this activity, students will learn how humans meet their needs in diverse habitats.
Objective 21: Life Science **Objective 24:** Personal and Social Perspectives in Science
Thinking Skills: Generate Ideas; Synthesize Elements

Description

Students record how their needs are met in their home, or habitat. Then they compare how these same needs are met in a place unlike their own home.

Materials

pictures of several human habitats different from the students' own

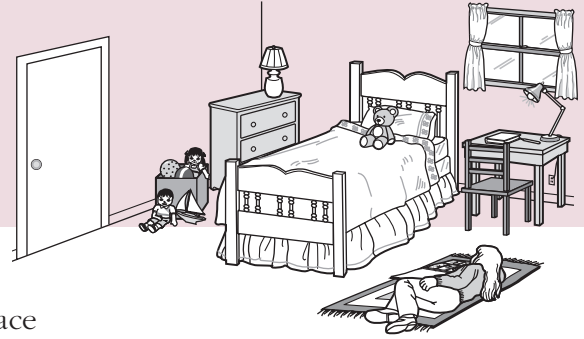
**Directions**

- 1. Getting Started** Tell students that a *habitat* is a place where humans or animals normally live and where their needs for living are met. For example, a worm's habitat is the soil and a fish's habitat is water.
- 2. Worksheet** Distribute copies of the worksheet. Write the following categories on the board: *shelter, food, fresh air, and clean water*. Discuss with students specific ways that their own needs are met where they live. Then have students write two ideas of their own for each category (shelter, food, fresh air, and clean water) in Chart 1 on the worksheet.
- 3. Show and Write** Present pictures of several human habitats that are different from the students' own. These may include an African village, a fishing boat on a Chinese river, a Bedouin tent in an oasis. Show pictures of people going about their daily lives in these environments. Have students select one of the habitats shown in the pictures. Then ask students to fill out Chart 2 on the worksheet.
- 4. Conclude Activity** Ask students the following question:
 - ♦ What can people do if a habitat doesn't meet one or more of their needs? (People can change their habitat to get the things they need, or they can move.)

Variation

For students who have trouble making the leap from the general to the specific, ask questions such as the following:

- ♦ Where in your home can you get clean water?
- ♦ Where does your food come from?

Challenge students to distinguish between things in a habitat that are essential (shelter, food, air, clean water) and those that are secondary (television, etc.).

Name _____

A Home Makes a Habitat—Worksheet

Habitats and Resources

Chart 1—Student’s Home

Need	How needs are met at home
Shelter	
Food	
Fresh Air	
Clean Water	

Chart 2—In Another Habitat

Need	How needs are met in another habitat
Shelter	
Food	
Fresh Air	
Clean Water	

ACTIVITY

4

Comparing Weights

Purpose

In this activity, students will learn that a larger object doesn't necessarily weigh more than a smaller one.

Objective 20: Physical Science **Objective 19:** Science Inquiry

Thinking Skills: Analyze Information; Generate Ideas; Evaluate Outcomes

Description

Using a balance scale, the teacher weighs pairs of various small objects after students predict which of the two objects in a pair is heavier and tell why. The teacher should lead the students to an understanding of the role gravity plays in a balance scale.

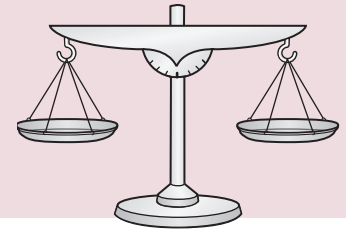
**Materials**

pencil, marble, cork, comb, and other small objects; balance scale

Preparation

Gather a number of small objects (at least half a dozen) that can fit on a balance scale and/or ask students to bring in objects from home. Be sure to include the items listed on the worksheet. Hand out copies of the worksheet.

Directions

- 1. Making Predictions** Choose a pair of objects at random. Ask students to predict which one weighs more. Continue with other pairs of objects. Have students record their predictions in the Predicting Weights chart on the worksheet. Ask students why they made each prediction. Get a show of hands for each prediction and record it on the board.
- 2. Collecting Data** Weigh the objects. Have students record the results (which object in each pair is actually heavier) in their charts. Determine whether the majority of the class predicted correctly. Discuss why the predictions were correct or incorrect.
- 3. Conclude Activity** Ask students the following questions:
 - ♦ Which weighs more—a marshmallow or a rock the size of a marshmallow?
 - ♦ Why do you think so? (Listen to the answers and reinforce those that indicate an understanding of the idea of density.)

Variation

Reinforce the concept that a larger object doesn't necessarily weigh more than a smaller one. Introduce the concept of density. Tell students that denser things have more "stuff" in the same volume than lighter things. Volume is the amount of space an object takes up. Have students examine objects and determine which ones they think have more or less volume, and which ones are denser.

Name _____

Comparing Weights–Worksheet

Predicting Weights

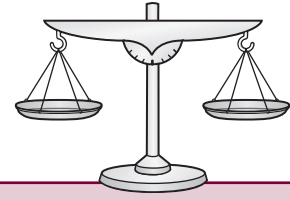

Object Pairs	Object I predict is heavier	Object that is heavier
pencil, marble		
marble, cork		
comb, cork		
pencil, cork		

ACTIVITY

5

Physical Properties of Objects

Purpose

In this activity, students will learn to classify objects by physical properties.

Objective 20: Physical Science **Objective 19:** Science Inquiry

Thinking Skill: Organize Information

Description

Students develop a variety of descriptive terms for each property. They then sort the objects by physical properties and record the descriptions on index cards.

Materials

index cards; objects such as a pen, a marble, a comb, a cork, a feather, a ball, a key, a button, a paper airplane, a chunk of clay, a ball of aluminum foil, a mitten, etc. (Use as many objects as there are students in the class.)

Preparation

Label index cards with the following descriptive headings: size, shape, texture, hardness, and color. Write the name of one object you have collected at the top of each card.

[Name of Object]

Size: Hardness:

Shape: Color:

Texture:

Directions

- 1. Getting Started** Explain to students that a physical property of an object is something they can experience through one of their five senses (sight, hearing, smell, touch, and taste). Tell students that objects have more than one physical property and that objects with similar physical properties can be grouped together (all smooth objects, for example).
- 2. Observe and Describe** With students, think of descriptive terms for each of the properties identified on the index card: size, shape, texture, hardness, and color. For example, for *texture*, descriptive words such as *smooth*, *rough*, *furry*, *sticky*, or *slimy* can be used. Record the descriptive terms for each physical property on the board.
- 3. Sorting Objects** Divide students into groups of 5 and provide each group with five objects. Have students take turns sorting objects by the descriptive terms for each physical property recorded on the board. On the card for each sorted object, have recorders in each group write the description of the object next to the relevant heading. For example, the first student might select *size*, then sort all the objects into small, medium, and large; the recorder would write these descriptions on the cards for these objects. Continue until all categories on all of the index cards are completed.
- 4. Conclude Activity** Give each student a completed index card. Ask a student to read aloud the properties of the object written on the card without naming the object. Have the rest of the class try to identify the object described. Repeat with the rest of the index cards, giving each student a turn to read the properties aloud. After completing the activity, ask students the following question:
 - ♦ Which physical properties were most helpful for identifying the objects?

Variation

Help students match different physical properties with the senses used to experience them. Ask questions such as the following:

- ♦ What sense would you use to tell if something is sweet?

Have students try to come up with other physical properties of objects besides the ones you have brainstormed.

ACTIVITY

6

How Well Does It Float?

Purpose

In this activity, students will learn which objects will float in water and whether objects that float will float better in fresh or salt water.

Objective 20: Physical Science **Objective 23:** Science and Technology

Thinking Skill: Evaluate Outcomes

Description

Students predict whether objects will float or sink in a container of water. Then, using identical containers—one of fresh water and one of salt water—students predict in which of the two containers the objects will float better (higher).

Materials

three identical containers: two with fresh water, the other with salt water (6 tablespoons per quart); small objects—eggs, things made of metal (keys, or small magnets), corks, bath toys, etc.

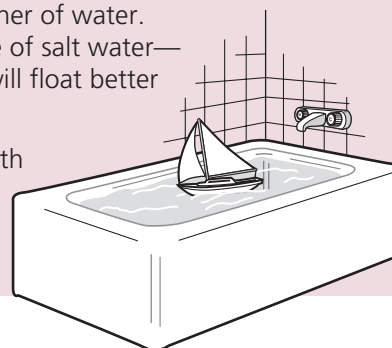
**Preparation**

Collect the objects needed for the demonstration. Prepare the three identical containers. Fill two containers with fresh water and the other container with salt water (made by dissolving 6 tablespoons of table salt per quart of water). Label one fresh-water container “A” and the salt-water container “B.”

Directions

- 1. Getting Started** Show students the array of objects. Ask students to predict which objects will float in plain water. Record predictions on the board (the number of students who voted “float” and the number of students who voted “sink”). Then place each object in the container to see if it floats. Compare results with predictions.
- 2. Predicting** Ask students to predict whether objects that float will float better (higher) in plain water or salt water. Tally their predictions on the board.
- 3. Collecting Data** Introduce the other two containers—the container of fresh water labeled A and the container of salt water labeled B—without revealing which one has the salt water. Float each object in both containers, recording which objects floated better in which containers. Ask students to guess whether container A or B contains the salt water and give the reasoning behind their guesses.
- 4. Examining Results** Place the containers in a warm, dry place until all the water evaporates from each one. Examine the containers with students to test their guesses about which container (A or B) contained salt water.
- 5. Conclude Activity** Explain that there are bodies of water, such as the Great Salt Lake in Utah, that are much saltier than ocean water. Ask the following questions:
 - ♦ Would you expect things to float better in the ocean, in a pond, or in the Great Salt Lake? (Great Salt Lake)
 - ♦ Why? (Objects are most buoyant when the salt concentration is highest.)

Variation

Have students think about when they played with toys in the bath. Which toys floated? Which toys sank? Tell students that whether an object sinks or floats does not depend solely on how heavy it is. It also depends on how big it is and how much water it pushes aside. Form a ball of clay, and demonstrate that it sinks in a container of fresh water. Ask students if it is possible to make the clay float in fresh water (without adding salt.) Demonstrate that clay can float by making it into a boat shape.

ACTIVITY

7

Our Closest Neighbor in Space

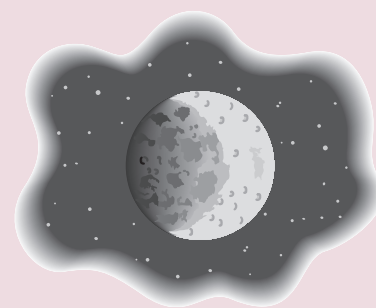
**Purpose**

In this activity, students will learn why we always see the same side of the moon and why the moon changes shape. They will also learn about the first landing of people on the moon.

Objective 22: Earth and Space Science

Objective 23: Science and Technology

Thinking Skill: Analyze Information

Description

Using a flashlight and a ball, students demonstrate why we always see the same face of the moon as it circles Earth and how much of that side we can see. Then students read about the first landing of people on the moon and answer three questions.

Materials

a large, white ball with a face drawn on one side; a large, powerful flashlight

Directions

- 1. Getting Started** Ask a student to come to the board and draw what the moon looks like. The student may draw a circle or a crescent. Have several other students draw different shapes of the moon.
- 2. Introducing Concepts** Tell students that it takes just less than a month for the moon to circle Earth. How the moon looks to us depends on where it is in its journey around Earth.
- 3. Modeling the Sun and the Moon** Ask for a volunteer to play the sun and a volunteer to carry a ball, which will represent the moon. The sun stands at the front of the room with a flashlight. Have the moon carrier stand a few feet in front of the sun, holding the moon so that the face is toward the class. (Make sure the moon carrier is holding the ball off to one side so as not to block the light.) Explain that the flashlight is the sun, the ball is the moon, and the rest of the class is on Earth. Also explain that the lighted part of the moon is the only part directly lit up by the flashlight.
- 4. Continue Activity** Have the moon carrier slowly circle the class, making sure that the face of the moon is always toward the center of the class. The flashlight should stay pointed at the moon as it moves.
- 5. Explain and Clarify** Explain that the same side of the moon always faces Earth because the moon spins exactly once on its axis in the same time it takes to circle the Earth. How much of that side we see depends on the position of the moon in relation to the sun. We see none of it when the moon is directly between Earth and the sun. We see all of it when Earth is between the sun and the moon. Between these two positions, we see different amounts of the moon.
- 6. Conclude Activity** Hand out copies of the worksheet and ask students to read the passage and answer the questions that follow.

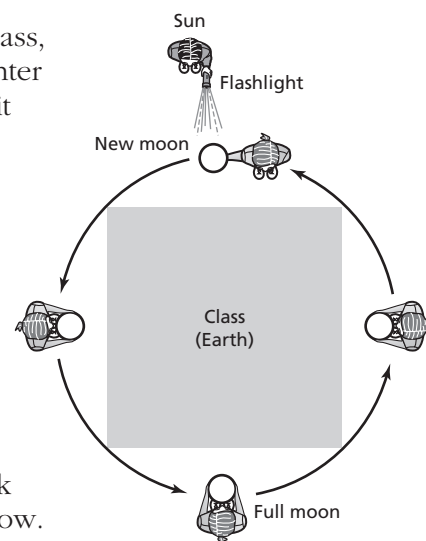
**Variation**

Remind students that the moon produces no light of its own but that it reflects light from the sun. Explain that the sun is much farther away from Earth than is the moon, and that the sun is never between Earth and the moon. Explain that the sun is much bigger than the moon but looks about the same size because it is so much farther away. Point out that mountains look small when you see them from a distance, and huge when you are close to them.

Name _____

Our Closest Neighbor in Space-Worksheet

A Special Trip

On July 16, 1969, three Americans set out on a special trip. They were going to the moon! Their trip was called the Apollo 11 Lunar Landing Mission. Lunar means “of the moon.”

Four days later, Neil Armstrong was walking on the moon. When he stepped on the moon, he said, “That’s one small step for man, one giant leap for mankind.” Soon, Buzz Aldrin joined him. Michael Collins was waiting for them in the spaceship.

Many people around the world watched the lunar landing on TV. There would be five more Apollo moon landings in the next few years.

Each landing was in a different place on the moon. But they were all on the same “face.” It is the face that we can see from Earth.

As the moon moves around Earth, it also spins. It takes exactly the same time to spin once as it does to circle Earth, so the same face is always toward Earth. The half of the moon facing away from Earth is the face we never see. Because of this, people sometimes call it the “dark” side, even though it gets light from the sun as often as the side we can see.

1 Why do we always see the same face of the moon?

2 What is the dark side of the moon?

3 Is that side always dark? _____

Explain your answer: _____

ACTIVITY

8

The Water Cycle and Acid Rain

Purpose

In this activity, students will learn how the water cycle works and understand where acid rain comes from.

Objective 22: Earth and Space Science

Objective 24: Personal and Social Perspectives in Science

Thinking Skill: Evaluate Outcomes

Description

Students observe the water cycle in miniature, using sand, water, and either sealed clear cups, a jar, or a terrarium.

Materials

large glass jar (or terrarium), clear plastic cups, plastic bags, rubber bands

Directions

- 1. Getting Started** Fill container(s) about 1/3 full with sand. Water liberally, soaking the sand thoroughly. Cover the container. Put it in a warm, sunny place.
- 2. Making Observations** Observe the container for several days. Water should condense on the sides of the container above the sand and on the lid, wrap, or bag. Ask students the following question:
 - ♦ Where does the water come from?
 Write their ideas on the board.
- 3. Introducing Concepts** Introduce the terms *evaporation* and *condensation* to describe what has happened inside the container. Tell students that what happens inside the container is similar to what happens on Earth. It is called the water cycle.
- 4. Worksheet** Hand out copies of the worksheet. Go over the steps and the terms with students. Have students read the paragraph, study the water cycle diagram, and answer the question.
- 5. Conclude Activity** Ask students to research on the Internet whether any areas in the state have been damaged by acid rain.



Variation

Ask students whether water is visible during all parts of the water cycle. Ask for explanations for both “yes” and “no” answers.

Name _____

The Water Cycle and Acid Rain-Worksheet

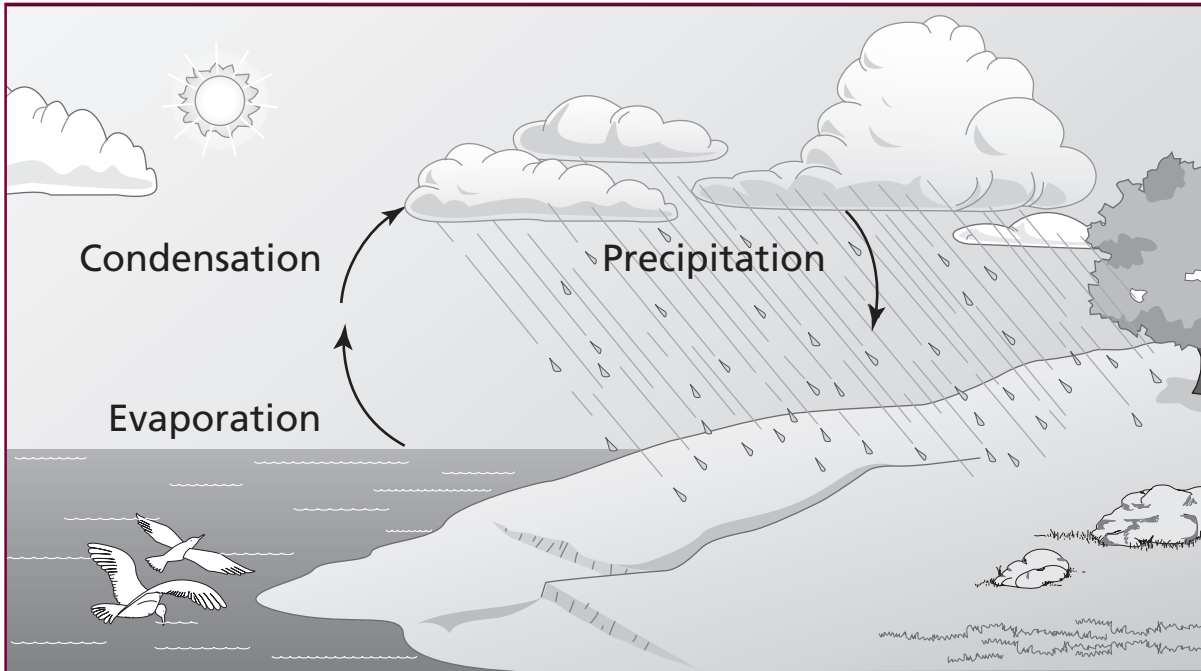

The smoke from factories goes into the air. It mixes with water and other things in the air and makes acids. These harmful chemicals are blown by the wind for miles and miles. Finally, they fall to the ground as snow, rain, or fog.

This is called *acid rain*. Acid rain hurts trees. It gets into the soil, and then plants cannot grow well. It kills fish and other animals in lakes and ponds.

Acid rain mixes with chemicals in the exhaust produced by cars and buses. City air becomes hard to breathe. Buildings become damaged.

Countries all over the world are trying to make less acid rain. They are trying to clean up the smoke that factories make. Progress has been made, but a lot of damage has already been done. It will be hard to get rid of acid rain.

What part does the water cycle play in acid rain?

Social Studies

Teaching Activities

Activity Number and Title		<i>TerraNova, The Second Edition</i> Objective Number and Title	Activity Worksheet	Activity Page Number
1	Using Maps	26 Geographic Perspectives	X	7.78
2	Nature's Gifts	26 Geographic Perspectives	X	7.80
3	Comparing Cultures	27 Historical and Cultural Perspectives	X	7.83
4	Home Sweet Home	27 Historical and Cultural Perspectives	X	7.85
5	Rules and Laws	28 Civics and Government Perspectives	X	7.88
6	Community Workers	29 Economic Perspectives	X	7.90
Answers to Student Worksheets				7.96

ACTIVITY

1

Using Maps

Purpose

Students use and interpret a map, a map key, map symbols, and cardinal directions.

Objective 26: Geographic Perspectives

Thinking Skills: Organize Information; Generate Ideas

Description

Students interpret a map of a playground and create and add symbols to the map and the map key.

**Directions**

- 1. Getting Started** Ask students how they would find their way around an unfamiliar place, without asking someone for directions. Inform students that although we most commonly think of maps of countries, states, and cities, a map can be a drawing of any place which shows where things are located. Give each student a copy of the worksheet.
- 2. Discuss Map Key** Tell students to look at the map key. Point out that a *symbol* is a small drawing that stands for the actual thing. Explain that a *map key* tells what each symbol means. Ask students to use the map key to answer the following questions about the map:
 - ♦ What is between the bench and the sandbox?
 - ♦ What is in the middle of the playground?
 - ♦ What is located in more than one area of the playground?
- 3. Discuss Compass Directions** Point out the compass rose in the corner of the map. Tell students that a *compass rose* shows the *directions* north, south, east, and west. Ask students the following questions:
 - ♦ Is the bench north or south of the sandbox?
 - ♦ Are the swings east or west of the tree?
 - ♦ Jay played basketball. Then he walked to the bench to rest. In which direction did he walk?
- 4. Student Work**
 - A.** Tell students that they will be adding symbols to the playground map. Go over the directions on the worksheet with the students. Give students time to complete this part.
 - B.** On the lines below the map, have the students write a question (similar to those asked in Step 3) that involves direction and the location of playground equipment. This may lead to discussions about intermediate directions such as northwest or southeast. Have students exchange maps with a partner. Have the students answer the questions written by their partners. Then have partners check their answers.
- 5. Conclude Activity** List different kinds of maps on the board: world, country, city, neighborhood, road, museum, etc. Ask students the following question:
 - ♦ How does each of these maps help you? (Responses should be on specific uses of each map, such as using a map at a shopping mall to locate a store.)

Variation

Basic Take students on a walk around the school playground. Ask students to bring some paper and a pencil. Help students make a map of the playground. Then, have them create a map key by drawing symbols for the objects on their map.

Advanced Have students use markers and large sheets of drawing paper to create a map of their classroom or the school. Remind them to include a map key.





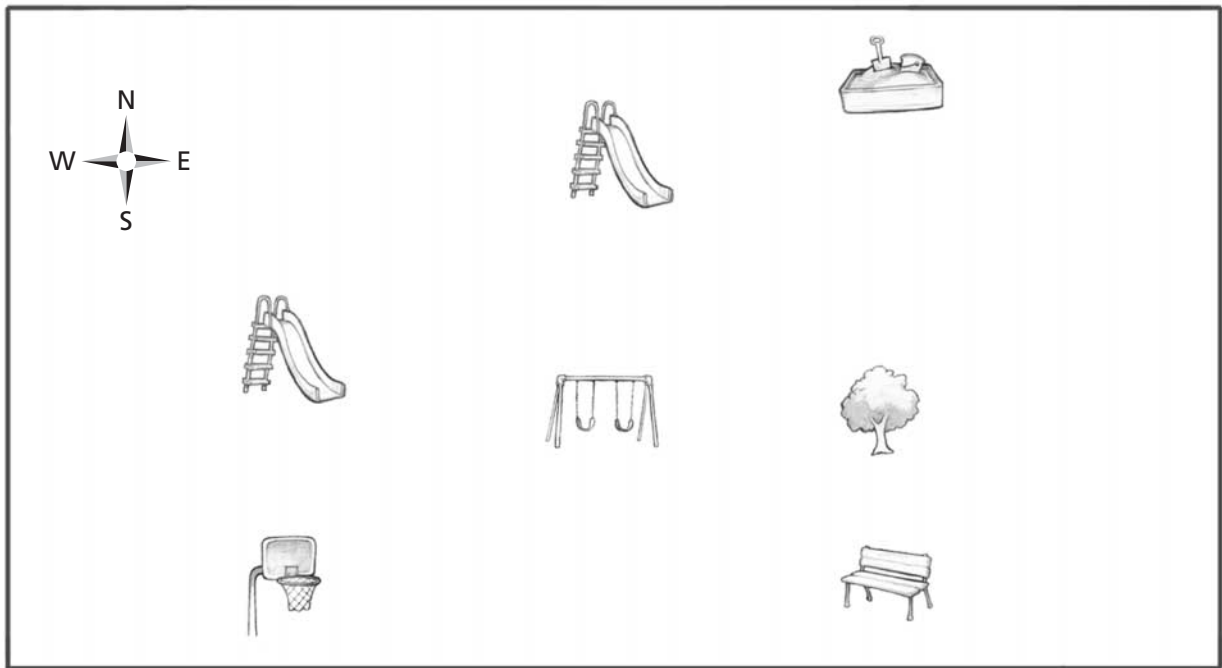

Using Maps—Worksheet

Directions:

- 1** Choose two of these playground objects: *jungle gym*, *drinking fountain*, *bike rack*, *hopscotch court*.
- 2** Make up symbols for the two playground objects and draw them in the boxes in the map key. Make the symbols simple and clear.
- 3** On the line next to each symbol, write the name of the playground object.
- 4** Draw the symbol for each playground object somewhere on the map.



KEY

	slide		basketball hoop		swings		sandbox
	bench		tree	<div style="border: 1px solid black; width: 60px; height: 60px; display: inline-block;"></div> _____		<div style="border: 1px solid black; width: 60px; height: 60px; display: inline-block;"></div> _____	

ACTIVITY

2

Nature's Gifts

**Purpose**

Students examine the importance of natural resources and identify ways to conserve them.

Objective 26: Geographic Perspectives **Thinking Skills:** Analyze Information; Generate Ideas

Description

Students complete a chart that lists general categories of natural resources. Students explain how the resources are used and how people can help protect them.

Directions

- 1. Getting Started** Organize the class into small groups and provide each group with a copy of Worksheet 1.
- 2. Worksheets 1 and 2** Tell students that anything that is found in nature and is useful to people is called a *natural resource*. Have students name the natural resources shown in the illustration on Worksheet 1. Read the names of the natural resources listed on Worksheet 2. Then, have students find examples of each natural resource in the illustration.
- 3. Group Work** Have the groups complete Worksheet 2.
 - A.** Have groups discuss how people use each natural resource. Have students write down their ideas in the second column.
 - B.** In the third column, have groups list ways to save or protect each natural resource. Remind students of the 3 R's: *reducing*, *reusing*, and *recycling*.
 - C.** Have groups share their results.
- 4. Conclude Activity** Ask students these questions:
 - ◆ What are some ways people can encourage others to save water? (by creating and displaying posters)
 - ◆ What does your community do to help trees and plants? (by organizing plant-a-tree campaigns)
 - ◆ How can garbage be used to help soil? (by composting garbage, which can be added to soil)

Variation

For several days, have students list or draw ways they conserve water or other natural resources at home and at school. Have each student draw a poster that would encourage people to preserve or conserve natural resources.

Name _____

Nature's Gifts-Worksheet 1

Directions: The picture below shows a farm scene. What natural resources are shown in the picture?



Name _____

Nature's Gifts-Worksheet 2

Directions: For each natural resource, tell how we use that resource. Then tell how we can protect it.

Natural Resource	A How We Use the Resource	B How We Can Protect the Resource
Air		
Water		
Soil		
Plants and Trees		
Animals		

ACTIVITY

3

Comparing Cultures

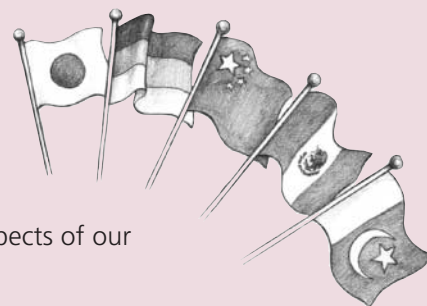
**Purpose**

Students demonstrate an understanding of the many cultures that have contributed to life in the United States.

Objective 27: Historical and Cultural Perspectives

Thinking Skills: Gather Information; Organize Information

Description

Students fill out a chart with information about different aspects of our culture and cultures of various other countries.

Materials

reference materials on various countries and cultures

Directions

- 1. Getting Started** Tell students that *culture* includes many aspects of life, such as language, holidays, foods, and games. Talk to students about how some aspects of our culture originated in the United States (e.g., Fourth of July, hot dogs) and how some originated elsewhere (e.g., spaghetti, soccer).
- 2. Explain and Discuss** Copy the chart below on the board. Explain to students that the chart lists different cultural features. Complete the chart by asking students to give examples of each cultural feature found in the United States.

Cultural Feature	United States
Foods	
Words	
Holidays	
Games/Sports	

- 3. Group Work** Divide the class into groups of two or three students. Distribute copies of the worksheet to each student. Tell students that there are many countries in the world and that they will be researching the cultures of some countries.
 - A.** On the board, list countries the students may research (e.g., Brazil, China, Egypt, England, France, Germany, Ghana, Greece, India, Ireland, Italy, Japan, Mexico, Russia, Spain, Vietnam). Assign each group two countries to research (or have student groups make their own country selections).
 - B.** Provide each group with books in which they can find information about these various cultures. Have students research each assigned country and complete the worksheet chart.
- 4. Conclude Activity** Ask students to write responses to the questions on the worksheet. (Answers will vary according to countries researched.)
Have each group share their information with the class.

Variation

For the countries they have researched, have students explore additional aspects of culture, such as art, music, and clothing.

Name _____

Comparing Cultures-Worksheet

Directions: Gather information about the cultures of the two countries you have been assigned. Complete the chart below by writing the names of the two countries and by listing some foods, words, holidays, and games or sports found in each country. Then use the chart to answer Numbers 1 and 2.



Cultural Feature	Country #1 _____	Country #2 _____
Foods		
Words		
Holidays		
Games/ Sports		

1 How are the cultures of these two countries different from each other?

2 How are the cultures of these two countries similar to each other?

ACTIVITY

4

Home Sweet Home

**Purpose**

Students match pictures of household objects from the past and present and trace patterns of continuity and change in home life in the United States.

Objective 27: Historical and Cultural Perspectives **Thinking Skill:** Organize Information

Description

Students play a game that compares life at home today in the United States with what it was like long ago.

Materials

scissors, paste, picture books containing images of household objects from the 1800s (optional)

Directions

- 1. Getting Started** Tell students that people today do many of the same things at home that were done long ago, but that today they are done in different ways. Have students look at pictures—in books, catalogs, or elsewhere—that depict life long ago (optional).
- 2. Read and Discuss** Read aloud each of the following sentences about home life long ago. Lead a discussion on how the same events would be different today.
 - ♦ Father drove the horse and buggy up to the front porch.
 - ♦ Mother milked the cow before breakfast so that we'd have fresh milk.
 - ♦ After school, Jesse had six chores to do, including chopping firewood.
- 3. Group Work** Give each student copies of Worksheets 1 and 2. Discuss with students each of the objects pictured on Worksheet 1, and be sure students understand the directions. Have students work in pairs. When students have completed the Worksheet 1 task, discuss with them the directions on Worksheet 2. When students have completed Worksheet 2, have volunteers share their answers.
- 4. Conclude Activity** Ask students to write a short paragraph, answering the following questions:
 - ♦ How have the inventions we use today changed people's lives?
 - ♦ What invention that we have today is most important to you—and why?
(Answers will vary according to inventions mentioned by the students.)

Variation

Basic In pairs, students cut out the pictures on Worksheet 1 and use them to play a Long Ago and Today game. All the pictures are placed facedown on a desk. One student begins the game by turning over a picture and then tries to match it by turning over another picture with the corresponding household object (e.g., quill pen and paper/computer). If the student makes a match, the turn continues and he or she tries to make another match. If the student does not make a match, the pictures should be turned back over in the same place. It is now the other student's turn. The point of the game is to remember which pictures match and where they are on the desk.

Advanced Have students create a set of pictures comparing life at school long ago with what it is like today.

Name _____

Home Sweet Home-Worksheet 1

Directions: Cut out the pictures and sort them into two groups: objects used long ago and objects used today. Then, use Worksheet 2 for the next task.



computer



water pump



washboard and tub



kettle over fireplace



vacuum cleaner



kitchen sink



quill pen and paper



stove and oven

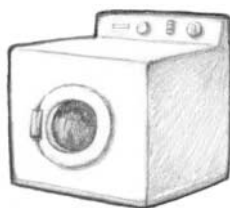

washing machine



rug beater

Name _____

Home Sweet Home-Worksheet 2

Directions: **1.** Paste the pictures of objects used long ago in the first column.
2. Match the pictures of objects used today with pictures pasted in the “Long Ago” column and paste them in the “Today” column.

Long Ago	Today

ACTIVITY

5

Rules and Laws

Purpose

Students demonstrate an understanding of rules and laws.

Objective 28: Civics and Government Perspectives

Thinking Skill: Analyze Information

Description

Students analyze situations that involve rules and laws.

**Directions**

- 1. Getting Started** Ask students the following questions:
 - ♦ Why do we have rules and laws? (to provide safety and order and to promote fairness)
 - ♦ What would happen if we had no rules and laws? (disruptions without classroom rules/traffic problems without laws)
- 2. Explain and Discuss Rules** Explain to students that there are different types of rules. Every family has rules. Every game has rules. Every school has rules. Ask students to provide examples of rules followed in a game or rules followed at school.
- 3. Discuss Laws** Explain to students that there are also rules that members of a community must follow. Explain that rules for a community are called laws. Ask students the following question:
 - ♦ What are some laws in our community? (traffic laws and other laws that allow people to live harmoniously in a community)
- 4. Student Work** Distribute copies of the worksheet. Go over the directions with the students and have students write their answers in the chart.
- 5. Conclude Activity** Have students share their answers with the class.

Variation



Have students make signs or posters illustrating a rule or law. Display these on the wall.

Name _____

Rules and Laws-Worksheet

Directions: The pictures below show people following some community laws. On the lines in the box next to each picture, explain why it is important to follow that law.

Community Laws

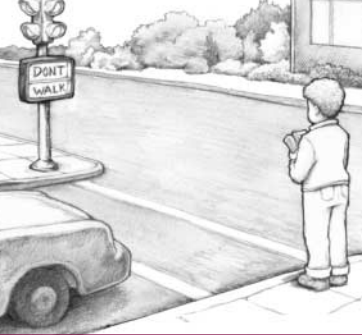
Community Law	Why is it important to follow this law?
	<hr/> <hr/> <hr/>
	<hr/> <hr/> <hr/>
	<hr/> <hr/> <hr/>

1 What is another law in your community that you think is important?

2 Why is it important to follow this law?

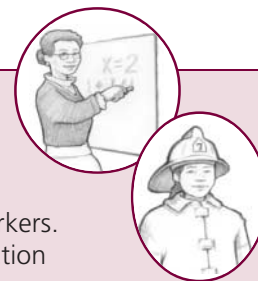

ACTIVITY

6

Community Workers

Purpose	Students learn about community services and the jobs of community workers. Objective 29: Economic Perspectives Thinking Skill: Analyze Information
Description	Students identify community service workers and describe the importance of their work.
Materials	books relating to various community service workers and their responsibilities (optional)

Directions

- 1. Getting Started** Tell students that the money a community or city collects from residents and businesses is called *taxes*. Explain that some of these taxes are used to pay people who work for the community and for community services.
- 2. Discuss** Have students think of services that are provided by their local government (e.g., police and fire protection, parks and recreation, public transportation).
- 3. Class Work** Distribute copies of the worksheet.
 - A.** As a class, discuss what each worker on the worksheet does and how that worker makes life better for people in the community. As a class, discuss other types of community workers and list them on the board (e.g., police officer, mayor, park ranger, librarian).
 - B.** Have students select one of the workers listed on the board. Have students write in the worker's job title on the line in the empty circle on the worksheet. Ask students to draw a picture in the circle of that community worker doing his or her job. Then, on the lines next to the picture, ask students to write down what that worker does.
- 4. Conclude Activity** Ask students the following question:
 - ♦ What do you think might happen if the community could not collect taxes? (Answers should focus on the effects of not having various community/city services.)

Variation

Help students make arrangements to interview a community service worker to find out more about his or her job. Before students conduct the interview, have them prepare several questions.

Name _____

Community Workers-Worksheet

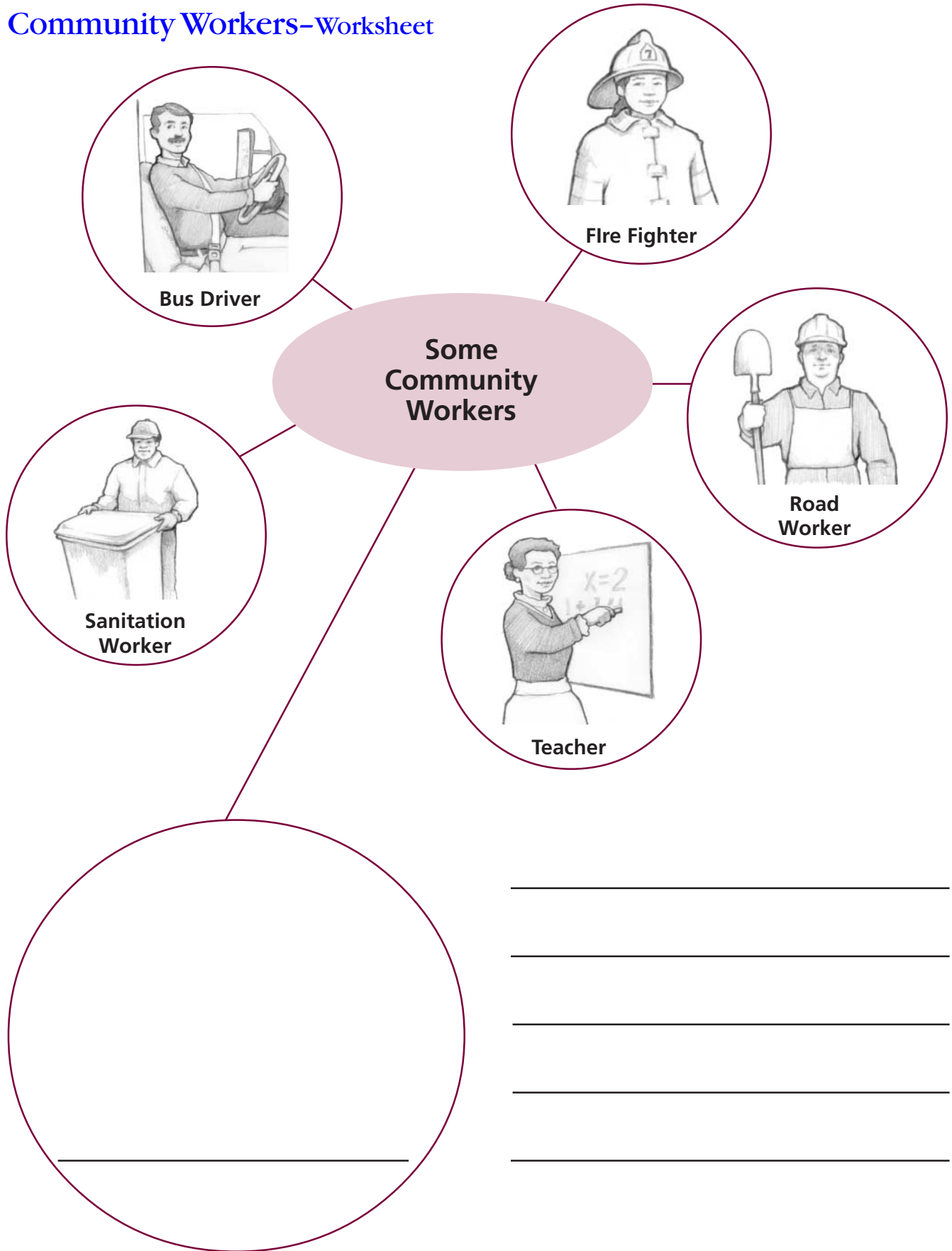

Copyright © 2002 by CTB/McGraw-Hill LLC.
This page may be reproduced for educational purposes only.

Answers to Student Worksheets

□ Reading and Language Arts

Activity 1: *no written answers for this worksheet*

Activity 2: Baby Elephant Goes to Tea

- Correct order for strips

First, Baby Elephant walked to Rabbit's house.
Then Baby Elephant put her foot in Rabbit's house.
Next, Baby Elephant put her head in and got stuck.
So then, Rabbit pulled Baby Elephant's tail and pulled her out of the house.

Baby Elephant landed on the ground outside.

Finally, Baby Elephant and Rabbit had tea and cake outside.

Activity 3: *no worksheet*

Activity 4: You Can Do It!

- Example of a completed chart

What the Character Does

Ava

She walks out on the stage.
She swallows hard.
She feels frightened.

Ava's mom

She tells Ava she is proud of her.
She reminds Ava she practiced hard.

What This Shows About the Character

Ava

It shows she is brave.
It shows she is nervous.
She doesn't feel like playing.

Ava's mom

She loves her daughter.
She wants Ava to be confident.

- Answers to the second worksheet

1. hard-working
2. funny
3. brave
4. careful
5. shy

Activity 5: *no written answers for this worksheet*

Activity 6: Kitten Care

- Answers for the chart will vary based on the pet selected.

Activity 7: What's That Word?

- Class discussion of definitions

Activity 8: The Treasure Hunt

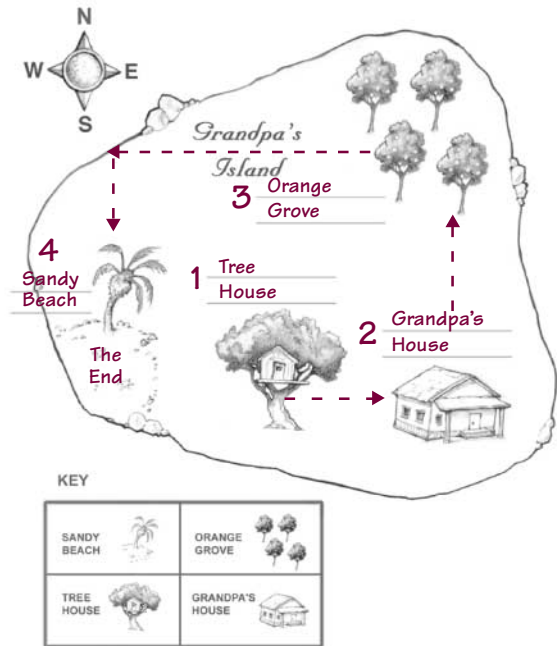

Activity 9: Making Words

- Completed ladder

8. crate
7. crane
6. lane
5. line
4. mine
3. mice
2. rice
1. race

Activity 10: Make Sentences Complete

- Possible corrections

My soccer team played against the Bears on Saturday. Many fans came. They cheered for both teams.

The Bears scored at the beginning of the game. We tried to stop them from scoring again. Our goalie did a good job. He blocked a great shot.

After we scored a goal, we were tied. We scored another point in the last five minutes. We won. The final score was 2 to 1! What an exciting game!

Activity 11: Put Them Together

• Possible sentence combinations

1. My grandmother and I wanted to go to the aquarium.
2. We waited in line and bought tickets.
3. We saw a swordfish and a jellyfish.
4. We didn't feed the otters or see the turtles.
5. The eels were strange looking, but the sharks were scary.
6. A diver went inside the big tank and fed all the fish.
7. Grandma bought postcards, but I bought a dolphin T-shirt.
8. My grandmother took lots of pictures, but I did not take lots of pictures.

Activity 12: Growing Vegetables

• Unnecessary sentences

Sand is made from pieces of rock.
My sister likes to put ketchup on her vegetables.
My dad works near a big park.

Activity 13: Mix It!

• Possible captions

1. Mix the peanut butter and honey together.
2. Mix in the granola and raisins.
3. Cover the bowl and put it in the refrigerator for thirty minutes.
4. Roll the mixture into little balls.
5. Roll the balls in the coconut.
6. Put the balls in the refrigerator for one hour.

Activity 14: Where Are the Capital Letters?

175 Birch Street
Somers, New York 10589

Dear Aunt Mary,

You won't believe what I did yesterday. Mom and Dad took Jeff and me to Dinosaur World! Dinosaur World is the best place. It is only six miles away, in Hinesville.

We rode a boat into a big cave. Inside the cave were huge dinosaurs that moved. The scariest dinosaur was Tyrannosaurus Rex.

I am going to Camp Greylock in June. I hope to see you in May. Maybe you can go with us to see the dinosaurs.

Love,
Kate

Activity 15: no worksheet**Mathematics****Activity 1: no worksheet****Activity 2: Place Value Patterns**

1. **233, 234, 235**, 236, 237
243, 244, **245, 246**, 247
253, 254, 255, **256, 257**
2. **565**, 566, 567, 568, 569
575, **576**, 577, 578, **579**
585, **586, 587**, 588, 589
595, 596, **597, 598**, 599
3. 249, 250, **251**, 252, 253
259, 260, **261, 262**, 263
269, 270, 271, 272, 273
279, 280, 281, 282, **283**
4. 422, 423, 424, 425, 426
432, 433, 434, **435**, 436
442, **443, 444**, 445, 446
452, 453, 454, 455, 456
462, 463, 464, 465, 466

Activity 3: Strategic Operations

Row 1: 34, 43, 47, 7

Row 2: 15, 12, 18, 39

Row 3: 79, 69, 88, 6

Row 4: 16, 13, 94, 50

Row 5: 25, 6, 25, 95

Row 6: 57, 6, 9, 16

Row 7: 34, 16, 79, 37

Row 8: 36, 19, 79, 9

- Strategies will vary.

Activity 4: no worksheet**Activity 5: What's the Problem?**

1. **$32 + 48 = 80$; Brandon's total score was 80.**
2. **$45 + 48 = 93$; Belinda's total score was 93.**
3. **$46 - 45 = 1$; Don beat Belinda by 1 point in the first game.**
4. **$50 - 48 = 2$; Carmen beat Brandon by 2 points in the second game.**
5. **$48 - 32 = 16$; Brandon scored 16 more points in the second game than in the first.**
6. **$50 - 42 = 8$; Carmen scored 8 more points in the second game than in the first.**
7. Responses will vary.

Activity 6: Daily Schedule

1. 2:00, 6:00, 4 hours
2. 10:30, 12:30, 2 hours
3. 8:45, 3:15, 6 hours 30 minutes
4. 9:45, 6:30, 8 hours 45 minutes
5. 5:00, 6:15, 1 hour 15 minutes

Activity 7: *no worksheet***Activity 8: Show-and-Tell Graphs**

1. 7 students
2. 5 students
3. 5 students
4. 1 student
5. 2 students
6. 2 students
7. 12 students
8. 11 students
9. 23 students

Activity 9: *no worksheet***Activity 10: Pick a Pattern**

1. You can count by 2s.
2. 3, 6, 9, 12, 15, 18, 21, 24, 27, 30
3. 6, 12, 18, 24, 30, 36, 42, 48, 54, 60
4. The numbers skip-count by 6.

Activity 11: *no worksheet***Activity 12: Time Capsule**

- All measurements are in inches.

Line A: 3
Line B: 1
Line C: 1
Line D: 3
Line E: 1
Line F: 5
Line G: 2
Line H: 2
Line I: 4

 Science**Activity 1: Insect Life Cycles**

- **Answers for second worksheet**
The correct order of the figures from left to right is 4, 1, 3, 2.

Activity 2: Name That Tree

- Drawings and answers will vary.

Activity 3: A Home Makes a Habitat

- **Answers for Chart 1**
How needs are met at home will vary.
- **Answers for Chart 2**
How needs are met in another habitat will vary.

Activity 4: Comparing Weights

- Students' predictions will vary.

Activity 5: *no worksheet***Activity 6:** *no worksheet***Activity 7: Our Closest Neighbor in Space**

1. The moon takes the same time to rotate on its axis as it takes to orbit Earth, so the same side faces us.
2. The dark side of the moon is the side ("face") we never see from Earth.
3. No. It gets light when it is facing toward the sun. For example, when the moon is between Earth and the sun, the "dark" side is fully lit.

Activity 8: The Water Cycle and Acid Rain

When the smoke goes into the air, it mixes with water vapor. Then it condenses in the clouds and falls to the ground.

□ Social Studies

Activity 1: Using Maps

- Students' drawings of symbols will vary.
- Student-created direction questions will vary, but may include:

Where is the jungle gym located?

In what direction would you go from the swings to the drinking fountain?

Activity 2: Nature's Gifts

- Answers for the second worksheet

Natural Resource—Air

How We Use the Resource

breathing

How We Can Protect the Resource

Share car rides.

Walk more.

Don't pollute it.

Pass anti-pollution laws.

Natural Resource—Water

How We Use the Resource

drinking, cleaning, playing, irrigation

How We Can Protect the Resource

Use less.

Turn off faucets.

Fix leaks.

Don't pollute. Pass anti-pollution laws.

Natural Resource—Soil

How We Use the Resource

growing plants

How We Can Protect the Resource

Don't litter.

Reduce garbage by recycling.

Plant certain plants for erosion control; build windbreaks and retaining walls.

Natural Resource—Plants and Trees

How We Use the Resource

food, paper, wood, clothing

How We Can Protect the Resource

Reuse paper bags.

Recycle newspapers.

Plant trees.

Natural Resource—Animals

How We Use the Resource

food, clothing

How We Can Protect the Resource

If you catch an animal or insect, don't keep it or kill it. Protect animals' environment by helping to prevent pollution.

Activity 3: Comparing Cultures

- Answers for worksheet chart will vary.
- Answers for worksheet questions will vary, but may include:

Differences: People eat different types of food.

Similarities: All people like to play games, celebrate holidays, etc.

Activity 4: Home Sweet Home

Correct pairings for pictures: water pump/sink; kettle over fireplace/stove and oven; washboard and tub/washing machine; rug beater/vacuum cleaner; quill pen and paper/computer

Activity 5: Rules and Laws

- Answers will vary, but may include:

Picture 1

Picture shows child disposing of trash in trash can.

Why is it important to follow this law?

To keep the city clean.

Picture 2

Picture shows a boy in a car, buckling his seat belt.

Why is it important to follow this law?

To keep passengers in the vehicle safe.

Picture 3

Picture shows pedestrian waiting on curb, obeying "Don't Walk" signal.

Why is it important to follow this law?

To keep pedestrians safe; to help keep drivers safe.

- Answers for worksheet questions 1 and 2 will vary, but may include:

1. Don't park in a handicap zone unless you have a permit.
2. It is reserved for people who may not be able to walk far.

Activity 6: Community Workers

- Illustrations and responses will vary.

Parents' Guide to Understanding *TerraNova, The Second Edition* Achievement Tests

Your child's class is participating in a test called *TerraNova, The Second Edition*, a standardized test given to students in schools across the nation. This guide is designed to help you understand the nature of the *TerraNova, The Second Edition* achievement test, what it asks your child to do, how to prepare your child for testing, and how to use the test results. It is intended to help you support your child during the testing process.

Q Why Test?

A Testing is an important part of education. *TerraNova, The Second Edition* provides objective information about each child's progress in four areas: Reading and Language Arts, Mathematics, Science, and Social Studies. When used in conjunction with other measures, such as classroom observations and teacher-made tests, the *TerraNova, The Second Edition* achievement test helps you and the teacher see your child's strengths and the areas needing improvement.

Q What Is the *TerraNova, The Second Edition* Test Like?

A *TerraNova, The Second Edition* is a standardized achievement test. It is always administered with similar questions, the same directions, the same time limits, and the same scoring criteria for all students. The results compare your child's performance with that of other students across the country.

The *TerraNova, The Second Edition* test differs from traditional achievement tests you may recall from your own experience by focusing assessment on what students can do, and not simply on speed. Every part of *TerraNova, The Second Edition* challenges students to apply basic skills and to interpret, synthesize, and evaluate information—all essential skills for the twenty-first century. In addition, testing times allow virtually all students to complete the test.

The *TerraNova, The Second Edition* format has been carefully designed to help students do their best work and move smoothly and efficiently through the test. For example:

- There are strong thematic connections among the items.
- Items are highlighted so students can locate them at a glance.
- Headings, directions, graphics, and item designs have been tested for clarity and helpfulness.
- Students are not required to turn pages to refer to source information for most items.

Your child may be asked to answer both selected-response (multiple-choice) and constructed-response items on the *TerraNova, The Second Edition* test. Selected-response questions ask your child to choose one answer from among those given as possible correct responses.

A Selected-Response Item

(Examiner reads directions aloud to students.)

Four carts were on top of a hill. The rope broke and three carts rolled downhill. Find the number sentence that tells how many carts were left on top of the hill.

1

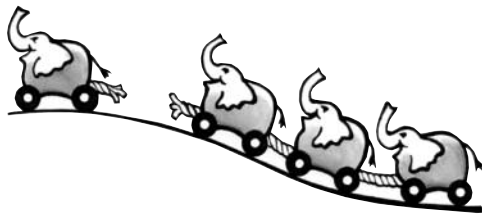

$4 - 3 = 1$	$3 + 1 = 4$	$4 + 1 = 5$	$3 - 1 = 2$
<input checked="" type="radio"/>	<input type="radio"/>	<input type="radio"/>	<input type="radio"/>

Constructed-response questions ask students to produce original responses to short-answer items or open-ended questions. Children may be asked to write an essay, produce a graph, or perform a science experiment.

A Constructed-Response Item

2 Geologists studying seismic waves have learned that the Earth is divided into distinct layers. Using the words in the box below, label each of Earth's layers.

Suppose you were able to drill a hole to the center of the Earth and examine a sample from each layer. Describe one characteristic you would observe for each layer.

- 1 _____
- 2 _____
- 3 _____

**Mantle
Core
Crust**

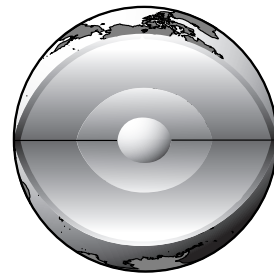

Q What Should I Know About *TerraNova, The Second Edition* Test Scores?

A *TerraNova, The Second Edition* achievement test scores are based on the overall pattern of correct responses. Pattern scoring accounts for which questions, what types of questions, and how many questions the student answers correctly.

Each student's results are presented as a national percentile rank. A percentile rank is a comparison score within a particular grade level. For example, if a student scored at the 65th percentile, this means he or she scored higher than 65 percent of his or her peers in the national sample group. A percentile rank does not refer to the percentage of items answered correctly.

Q How Can I Help My Child Prepare for the Test?

A While your child is the one who ultimately is responsible for his or her performance on a test, you can play an important role in helping your child prepare. The best approach, however, is to be matter-of-fact about the test. Your child should know what the test will be about, when it will be given, and how long it will take. Share the view that the test is an opportunity for students to show what they have learned so far in school.

Taking a test is hard work and takes a lot of energy. We recommend that your child get plenty of sleep and eat a nourishing breakfast and lunch on test days. Be sure he or she is at school on time, and remember to ask about the testing each day.

Q How Can I Use the Test Information?

A You can help your child benefit from the results in several ways:

- Compare the test results with your child's class work, projects, tests, and other school achievements completed close to the time of the *TerraNova, The Second Edition* test. Look for similarities and differences.
- Use information about specific strengths and challenges to help your child set learning goals.
- Ask the teacher about specific ways you can work together to build on your child's strengths and to increase competence in areas needing improvement.

□ Remember

Above all, remember that the *TerraNova, The Second Edition* test represents a "snapshot" of your child's achievement—it is only one measure of your child's progress. Teacher observation, results of class tests, and class participation, for example, are equally important measures of your child's progress.